

**Nextel®**

*Digital Multi-Service Data-Capable Phone*

***i1000plus* User's Guide**

**Final Draft**

**March 22, 1999**

# CONTENTS

<b>Welcome to Nextel</b> .....	<b>1</b>
Features of Your <i>i1000plus</i> .....	2
Learning to Use Your <i>i1000plus</i> .....	4
Activating Your <i>i1000plus</i> .....	4
Attaching and Charging the Battery .....	5
Charging the Battery .....	5
Disconnecting the Travel Charger .....	5
Battery and Charging Status .....	6
Detaching the Battery .....	6
Turning On Your <i>i1000plus</i> .....	6
Your Nextel Phone Status .....	6
Turning Off Your <i>i1000plus</i> .....	7
Display Icons .....	8
About Modes and Menus .....	9
Setting the Time and Date Format .....	9
Changing the Display Language .....	11
<b>Phone Calls</b> .....	<b>12</b>
Programming Your Own Phone Number .....	12
Making Phone Calls .....	13
Using Other Dialing Methods .....	14
Last Number Redial .....	14
Turbo Dial™ .....	15
Automatic Redial .....	15
Emergency Dial .....	15
Non-Emergency Dial .....	15
Hands-Free Speakerphone .....	16
Receiving a Phone Call .....	17
Missed Call Indicator .....	17
Setting the Ringer Volume .....	18
Selecting a Ring Style .....	18
Selecting a Ring Style for the Alternate Line .....	18
VibraCall .....	19
Creating, Editing and Using Stored Lists .....	21
Combined Phone Number and Private ID List Programming .....	21
Editing and Erasing Phone List Entries .....	23
Editing and Erasing Private ID List Entries .....	23
Last 10 Numbers Received/Sent Call List .....	24
Quickstore of Phone Numbers .....	25
Quickstore of Private IDs .....	26

<b>Additional Phone Services</b> .....	<b>27</b>
Call Waiting .....	27
Call Hold .....	28
3-Way Calling .....	28
Call Forwarding .....	28
Transferring Calls to Voice Mail .....	29
Caller ID .....	29
Using an Alternate Line .....	30
<b>Nextel Voice Mail</b> .....	<b>32</b>
Setting Up Your Voice Mailbox for the First Time .....	32
Sample Greetings .....	33
Accessing the Voice Mail Service After Set Up .....	33
Receiving New Voice Mail Messages .....	34
Viewing Voice Mail Message Status in Your Mailbox .....	34
Nextel Voice Mail Features .....	36
Playing Messages .....	36
Sending Messages .....	38
Acceptable Destination Addresses .....	38
Recording and Sending Messages .....	39
Special Delivery Options .....	39
Urgent .....	40
Private Delivery .....	40
Notification of Non-delivery .....	40
Future Delivery of Messages .....	41
Greetings .....	41
Group Lists .....	43
Pager Notification .....	45
Personal Password and Name Response Options .....	46
Changing your Password .....	46
Name Response Options .....	46
Message Forwarding .....	46
Caller Options .....	47
Voice Mail Time and Dates .....	48
<b>Using Text and Numeric Paging</b> .....	<b>50</b>
The Nextel Paging Advantage .....	50
Page Delivery .....	50
How to Use Nextel Text and Numeric Paging .....	50
To Send a Page .....	50
Notification of New Text and Numeric Pages .....	52
Retrieving New Pages .....	52
Viewing Your Text and Numeric Pages Status .....	53

Auto Call Back .....	53
<b>Nextel Direct Connect .....</b>	<b>55</b>
Programming Your Own Private ID .....	55
Nextel Direct Connect Private/Group Speaker .....	55
Private Calls .....	56
Making Private Calls .....	56
Cover Closed .....	56
Cover Open .....	56
Receiving a Private Call .....	57
Call Alert™ .....	57
Call Alert Queuing .....	58
Group Calls .....	59
Making a Group Call .....	59
Receiving a Group Call .....	60
Adding and Storing a Talkgroup .....	61
Group-Silent Programming .....	61
<b>Using Your Phone as a Modem .....</b>	<b>62</b>
<b>Programming Menus .....</b>	<b>63</b>
<b>Accessories .....</b>	<b>69</b>
Batteries .....	69
Travel Charger .....	70
Cigarette Lighter Adapter .....	71
Desktop Dual-Pocket Charger .....	72
Audio Adapter .....	73
<b>Other Useful Information .....</b>	<b>74</b>
Nextel Customer Care .....	74
Understanding Status Messages .....	75
Terms and Conditions of Service .....	76
<b>Safety and General Information .....</b>	<b>79</b>
Safety and General .....	81
Accessory Safety Information .....	84
<b>Owner's Information .....</b>	<b>86</b>
Private Call Directory .....	87
Talkgroup Directory .....	87

## Patent and Trademark Information

This product is protected under one or more of the following patents:

4817157, 4896361, 4857928, 5041793, 5060294, 5066923, 5134718, 5140156, 5239963, 5257411, 5287387, 5265219, 5289504, 5316168, 5317247, 5338396, 5389927, 5406588, 5424921, 5457376, 5460906, 5551063, 5557079, 5596487, 5615412, 5638403, 5559468, 5469465, 5170413, 5140615, 5519730, 5241544, 5584059, 5574992, 5396656, 5487091, 5533004, 5299199, 5343499, 5369501, 5509031, 5515379, 5528723, 5598417, 5066923, 5241650, 5278833, 5359696, 5548631, 5410632, 5440582, 5457735, 5457818, 5471670, 5477550, 5481537, 5566181, 5229767, 5208804, 5295140, 5381449, 5440590, 5467398, 5490230, 5620242, 5623523, 5655913, 5715240, 5771440, 5854578, 5675281

Additional patents are pending.

© 1999 Nextel Communications, Inc. All rights reserved. Nextel, the Nextel logo, Nextel Direct Connect, NexNote, NexNote Plus, and Nextel Business Networks are trademarks and/or service marks of Nextel Communications, Inc. [www.nextel.com](http://www.nextel.com)

™, Motorola, iDEN, Call Alert, i1000plus, TurboDial, VibraCall, and Message Mail are trademarks or registered trademarks of Motorola, Inc.

®Reg. U.S. Pat. & Tm. Off.

*All other trademarks mentioned in this manual are trademarks of their respective companies.*

### **Important!**

Be sure to read "Safety and General Information" on page 79 before using your Nextel phone.

© Copyright 1999, Motorola, Inc. All rights reserved.

# WELCOME TO NEXTEL

**T**hank you for choosing Nextel as your wireless communications provider. The *i1000plus* is one of the most sophisticated digital cellular phones available today, offering you a range of unique, state-of-the-art features.

This guide contains all the information you need to take full advantage of your Nextel service, including:

- **Digital cellular calling** for crystal-clear connections and built-in call security on the all-digital Nextel National Network
- **Nextel Direct Connect<sup>SM</sup>**, an exclusive feature for communicating instantly with one or more co-workers at a fraction of the cost of cellular
- **Voice Mail** to keep you from missing important calls
- **Text and Numeric Paging** to help you stay connected — even when you don't have time to talk on the phone
- **Speakerphone** feature for hands-free communication
- **Alternate Line** capability to help you better manage your business, personal and most important calls
- **3-Way Calling** to easily conference with two other parties
- **Dial-up Services** capability without Landline Access (see the *Nextel Online Dial-up Services User's Guide*)
- **Net mode** to access Nextel Online Internet Services (future availability)
- You'll also find details on other Nextel features:
  - The all-digital Nextel National Network
  - No roaming fees
  - One-second call rounding after the first minute
  - Flat-rate long distance pricing anywhere in the continental U.S.
  - No landline connection charges

You can use various features of your *i1000plus* with the cover open or closed. Look for special operating instructions in this guide.

For more information about Nextel or to view this guide on our web site, visit us at [www.nextel.com](http://www.nextel.com).

TTY access for hearing-impaired users is available with your *i1000plus*. See the *Nextel Online Dial-up Services User's Guide* for complete instructions.

## **Questions?**

Call Nextel Customer Care at 1-800-639-6111, or dial 611 from your *i1000plus*.

## Features of Your *i1000plus*

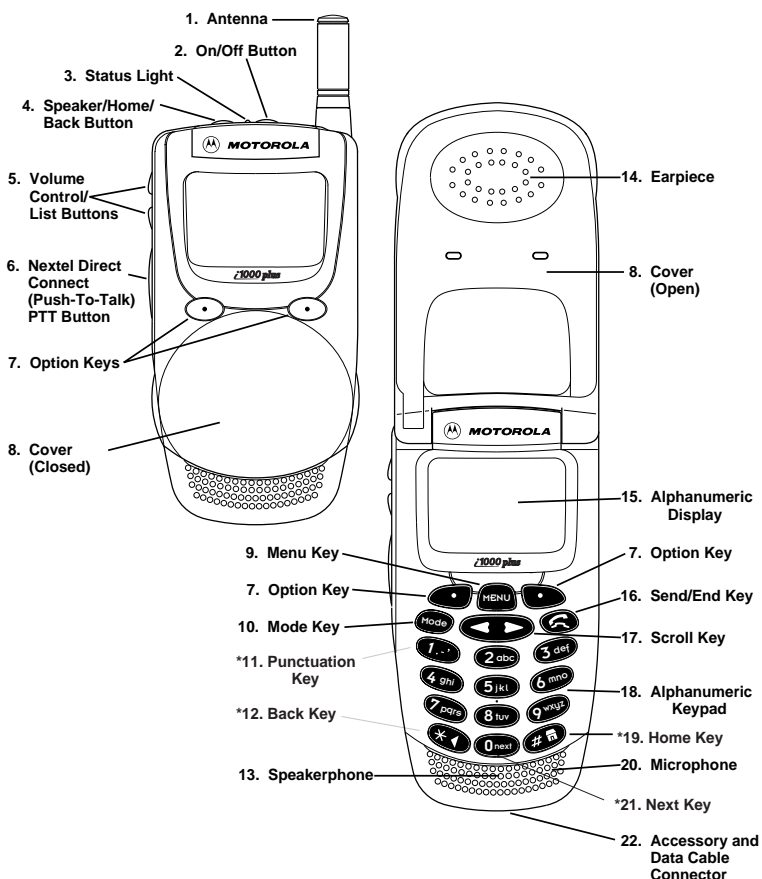

\*Applies to Nextel Online Internet Services; future availability

### NOTES:

- Remove the three plastic film lens protectors from the display and cover before you use your *i1000plus* for the first time.
- The display backlight is activated by pressing any key or button.

1.	<b>Antenna</b>	Extend for optimal signal.
2.	<b>On/Off Button</b>	Press and hold to turn your <i>i1000plus</i> on or off.
3.	<b>Status Light</b>	Check the status of your connection. See Table 2 on page 7 for more information.
4.	<b>Speaker/Home/Back Button</b>	Press to listen to Nextel Direct Connect calls through either the earpiece or the speaker during Private and Group calls.
5.	<b>Volume Control/List Buttons</b>	Press to adjust volume levels in Phone, Private, and Group modes and to scroll through lists.
6.	<b>Nextel Direct Connect (PTT) Button</b>	Press to transmit a Private or Group Call, or a Call Alert™. Press and hold to talk; release it to listen.
7.	<b>Option Keys</b>	Press to select a menu option on the display that appears directly above the left or right option key.
8.	<b>Cover</b>	Close the cover to protect the keypad or end a phone call.
9.	<b>Menu Key</b>	Press to scroll through menu options.
10.	<b>Mode Key</b>	Press to change modes (Phone, Private, Group, Net (for future functionality)).
11.	<b>Punctuation Key</b>	For future functionality.
12.	<b>Back Key</b>	For future functionality.
13.	<b>Speakerphone</b>	Listen to calls during speakerphone or Nextel Direct Connect calls.
14.	<b>Earpiece</b>	Listen to calls when the speakerphone or the Nextel Direct Connect speaker is off.
15.	<b>Alphanumeric Display</b>	View up to four lines (12 characters per line) or six lines (16 characters per line) on the display in Mail Services and Net Mode (future availability).
16.	<b>Send/End Key</b>	After entering a phone number, press to make a phone call or redial the number. Press to answer incoming phone calls. Press to end phone calls.
17.	<b>Scroll Key</b>	Press the left side to scroll backward or the right side to scroll forward through menu options and lists. When entering text, press to erase text or add a space.
18.	<b>Alphanumeric Keypad</b>	Enter telephone numbers, Private Call IDs, and alphanumeric characters.
19.	<b>Home Key</b>	Use to change lettercase when entering text. Also, for future functionality in Net Mode.
20.	<b>Microphone</b>	Speak into during calls.
21.	<b>Next Key</b>	For future functionality.
22.	<b>Accessory and Data Cable Connector</b>	Connect accessories and the data cable.

## Learning to Use Your *i1000plus*

This User's Guide is designed to help you learn about the features of your new *i1000plus*. By reading it now, you'll be able to take full advantage of all the benefits your Nextel service provides for you and your company.

You will find a handy Quick Reference Guide attached to this manual to help you get started on your *i1000plus* right away.

Or, you can view the short video to learn the basics of using your *i1000plus*, then refer to the User's Guide later for more in-depth information.

## Activating Your *i1000plus*

Before you can begin using your *i1000plus*, it needs to be activated.

- If you purchased your phone through a Nextel Sales Representative, your phone should be active already.
- If there is a separate activation sheet in this package, simply follow the step-by-step instructions included.

If your display reads "No Service" or doesn't change to the "Phone Ready" screen when you turn on your phone and you know you are in a Nextel coverage area, call Nextel Customer Care at 1-800-639-6111.

---

**NOTE:**    **For first time users:**

To properly register for the first time on the network, you must turn on your *i1000plus* in your local calling area prior to traveling.

---

## Attaching and Charging the Battery

To get the maximum use from the battery, charge it for at least three hours before you use it for the first time. After the initial charging, the battery can be charged more quickly.

Remove the battery from the protective case provided in the original packaging. When the battery is not attached to the phone or being charged, store it in this case.

### Attaching the Battery

To attach the battery to your *i1000plus*, align the battery as shown. Press down on the battery until you hear a click.

---

**NOTE:** The battery can be charged with the *i1000plus* either turned on or off. For best results, charge it with the phone turned off.

---

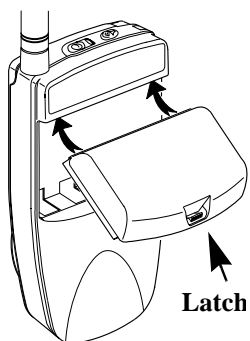

### Charging the Battery

To charge the battery using the Travel Charger:

1. Make sure your *i1000plus* is facing you.
2. With the @ logo on the accessory connector facing you, plug the accessory connector into the bottom of the *i1000plus*.
3. Flip open the prongs and plug the charger into an AC outlet.

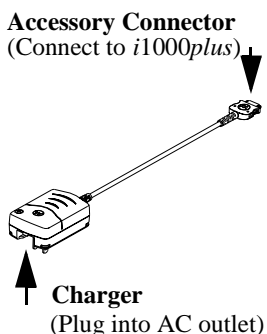





### Disconnecting the Travel Charger

To disconnect the Travel Charger, squeeze the side tabs of the accessory connector and pull out.

## Battery and Charging Status

A low battery is indicated by a short, chirp-like sound through the speaker. The battery strength indicator icon shows the remaining charge in your battery. Three bars indicate full charge. As the charge is reduced through use, the bars disappear. The indicator flashes when you have less than five minutes of talk time remaining.

**Table 1: Battery Charging Status**

	 Icon Flashes				
<b>Charging</b>	<b>Low Battery</b>	<b>0-30%</b>	<b>31-60%</b>	<b>61-90%</b>	<b>91-100%</b>
<b>Discharging</b>	<b>Low Battery</b>	<b>0-10%</b>	<b>11-40%</b>	<b>41-70%</b>	<b>71-100%</b>

## Detaching the Battery

To detach the battery, press the latch to release the battery and slide the battery downward.

## Turning On Your i1000plus

After your battery is fully charged, turn on your phone by simply pressing and holding the On/Off button  on top of the phone.

A set of icons appears briefly on your display, followed by a “Welcome to Nextel” message, and then a “Please Wait Connecting” message.

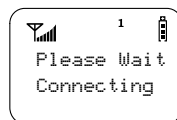

Within seconds, your phone will sign on to the Nextel National Network and “Phone Ready” will appear in the display area. Now, you’re ready to use your i1000plus!

## Your Nextel Phone Status

As you turned on your i1000plus, you may have noticed a light flashing next to the On/Off button on top of the phone. It’s the “Status Light” indicator that shows you the status of your connection at a glance. See Table 2 on page 7.

Table 2: Status Light Indicator

Status Light Indicator	Nextel Phone Status
Flashing Red	Registering—your <i>i1000plus</i> is signing on to the Nextel National Network. Please wait.
Solid Red	No service—your <i>i1000plus</i> cannot sign on. If you are in a Nextel coverage area, keep your phone on and it will continue trying to connect every two minutes as long as your phone is turned on. If this continues for 15 minutes or longer, call Nextel Customer Care at 1-800-639-6111. <b>Note:</b> If you are not in a Nextel coverage area, you will also see a red light.
Flashing Green	In service—your <i>i1000plus</i> is ready to use. You're on the Nextel National Network! You can now place and receive calls. <b>Note:</b> Direct Connect (Private and Group) calls are not available outside your home market area.
Solid Green	In use—your <i>i1000plus</i> is currently being used. To make sure that you ended the last call, press  .

## Turning Off Your *i1000plus*

Press and hold the On/Off button  until you see the message “Powering Off”.

## Display Icons

After you turn on the phone, icons appear on the display to inform you of existing conditions. See the following list.

The following icons may appear on the display.



### Signal Strength Indicator

Shows the signal strength. Six bars indicate the strongest signal. Calls and messages may not be sent or received when there is no signal.



### Battery Strength Indicator

Shows the remaining charge in your battery. Three bars show full charge. The indicator flashes when you have less than five minutes of talk time remaining.



### Voice Mail

Indicates that you listened to but did not save or delete messages. A flashing voice mail icon indicates that unplayed messages are waiting in your voice mailbox.



### New Text and Numeric Paging

Indicates that you have new incoming pages.



### Unread Text and Numeric Paging

Indicates that you have unread pages.



### Vibration (VibraCall™)

Indicates that the Vibrate All option is turned on. Your i1000plus will vibrate instead of giving you a ring tone.



### Active Line Indication

Indicates the active phone line (1 or 2).



### Call Forward

Indicates that incoming phone calls are being forwarded and displays the phone lines forwarded (1, 2, or both).



### Private/Group Speaker

Indicates that the Private/Group speaker is off. You will hear Nextel Direct Connect calls through the earpiece.



### More Information

Indicates that there is more text to read above, below, or above and below the current screen.

## About Modes and Menus



Your *i1000plus* operates in four different modes: Phone, Private, Group, and Net (*future availability*). By switching modes, you can use your *i1000plus* for different operations: phone calls, private and group calls, and Nextel Online Internet Services (*future availability*).

If the word “Ready” does not appear after the mode name in the display, your unit is not ready.

To switch between these modes:

- With the cover closed, press the option key under “Mode”.
- Or, open the cover and press .

To use menu options:

- With the cover closed, the menu options change as you press the option keys under the menu options.
- With the cover open:
  1. Press .
  2. Press  to scroll through the available menu options for the selected mode.
  3. Press  under the displayed menu option that you wish to select.

## Setting the Time and Date Format

**IMPORTANT:** The Time and Date may not be available in your area and may not appear on your display. Once this feature becomes available, your *i1000plus* will automatically display the local time and date.

You have a choice of a 12- or a 24-hour clock format. See Table 3.

**Table 3: Time Display Options**

12-Hour Display	24-Hour Display
12:00a	00:00
6:25a	06:25
12:00p	12:00
10:25p	22:25

After this feature is activated, you have a choice of either a MM/DD (month/day) or a DD/MM (day/month) date format. See Table 4.

**Table 4: Date Display Options**

Date	Month/Day Format (MM/DD)	Day/Month Format (DD/MM)
January 2nd	01/02	02/01
December 31st	12/31	31/12

After this feature is activated, all modes (Phone Ready, Private Ready, Group Ready, Net Ready) display the time and date on the third line of the display.

To set the time and date format:

1. Press **\*←**, **#**, **7 PQRS**, **1.**
2. Press **○** under "Ok". The Time/Date screen displays.



*The default (preset) time and date format is set to "On". However, the time and date does not display until the Nextel National Network activates this feature.*

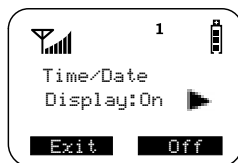

3. Press **▶** until you see the Time Format screen.
4. Do one of the following:
  - To use the 12-hour format, go to the next step.
  - To use the 24-hour format, press **○** under "24hr". (See Table 3 on page 9.)

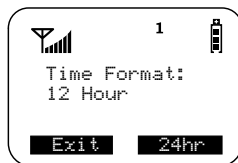

5. Press **▶** until you see the Date Format screen.
6. Do one of the following:
  - To use the MM/DD format, press **○** under "Exit".
  - Or to use the DD/MM format, press **○** under "DD/MM". (See Table 4 on page 10.)

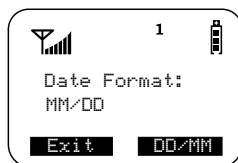







7. Press **○** under "Exit". The Phone, Private, Group, and Net Ready screens now display the selected time and date formats.

## Changing the Display Language

You can customize your *i1000plus* to display menus in English, Spanish, French, or Portuguese. The default language is English.

To change the displayed language:

1. Open the cover.
2. Press  ,  , , .
3. Select “Ok”.
4. Press  to scroll through the language options.

*Selecting “Exit” at any time retains the current language selection.*

5. When the desired language appears on your display, select “Ok”. The displayed text immediately changes to the selected language.
6. Select “Exit” (in the language selected) to exit this menu.



## PHONE CALLS

In addition to making and receiving phone calls in various ways in Phone mode, you can make emergency and non-emergency calls, be notified of a missed call, select ring style notification, set VibraCall, and more.

You can receive incoming phone calls while the *i1000plus* is in any mode, and you can make a phone call with the cover closed or open.

You must be in “Phone Ready” mode to make and receive phone calls.



(cover open)

## Programming Your Own Phone Number

Before you get started using your *i1000plus*, you may need to enter your own phone number so you can refer to it later if necessary. This is a one-time activity that can be performed using the following instructions. Or, you can wait for your first incoming call, when it is automatically entered.

---

**NOTE:** If your Nextel phone has two lines, your phone number for the second line will not be automatically entered with the first incoming call to that line. You must manually program it in. First select the line for the phone number that you want to program, and then continue. For more information, see “Using an Alternate Line” on page 30.

---

1. To store your phone number in your Nextel phone (or the alternate line, if you have two lines), press **\*←, #, 1, .**.
2. Press **•** under “Edit”.
3. Enter your phone number.
4. Press **•** under “Store”.
5. Press **•** under “Exit”.

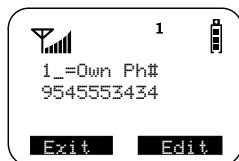

---

**NOTE:** To display your phone number at any time, press



**\*←, #, 1, .**

---

## Making Phone Calls

### Cover Closed



To place a call with the cover closed, you must have a stored phone number. For more information, see “Creating, Editing and Using Stored Lists” on page 21.



1. Press  under “List”.
2. Use the Volume Control buttons to scroll through your Phone list until you see the desired name or number.
3. Press  under “Dial”. When the call connects, the speakerphone is activated. *For a private conversation, open the cover and use the earpiece.*
4. To end the call, press .

### Cover Open

You can place a call by entering the phone number on the keypad (Direct Dial).

1. Enter the number you wish to call.

*If you make a mistake, press  to move back one digit at a time, or press  under “Cancl” to start over.*



2. Press  to place the call.
3. To end the call, press  or close the cover.







## Using Other Dialing Methods

**IMPORTANT:** After creating a phone list as described in “Creating, Editing and Using Stored Lists” on page 21, you have the following additional options to make a call.





### *Scroll*

1. Press  to scroll backward or forward through the stored list of numbers and names.
2. Press  to place the call.
3. To end the call, press  or close the cover.

### *Speed Dial*

1. Press  until you see the “Spd#” option.
2. Press  under “Spd#”.
3. Enter the assigned speed-dial number (1-100). You will see the name and phone number associated with the speed-dial number.
4. Press  to place the call.
5. To end the call, press  or close the cover.

### *Name Search*

1. Press  under “Name”.
2. Using the keypad, enter the first letter of the desired name, for example, to search for the name Bob:
  - a. Enter “B” by pressing  until you reach the “B” listings.
  - b. Press  to scroll through all the names starting with “B” until you see “Bob”.
3. Press  to place the call.
4. To end the call, press  or close the cover.

### *Last Number Redial*

To redial the last number that you called, simply press .

## Turbo Dial™

Turbo Dial allows you to call any one of your first eight entries in the Phone List directory by pressing and holding the corresponding numeric key (1-8) on the keypad for two seconds, thus automatically dialing that phone number.

- Press and hold the numeric key (1-8) associated with the number you wish to dial.
- The phone begins to dial the number.  
For example, press **1** for speed dial #1. *Keypad numbers 0 and 9 are not available for Turbo Dialing. Pressing and holding **9** will result in emergency dialing to 911.*

## Automatic Redial

If you receive a “System Busy, Try Later” message, press  to have your phone automatically redial the number. You will hear a ring-back tone when the call is successful.

## Emergency Dial

The Emergency Dial feature allows you to call the 911 emergency phone number by pressing and holding **9** for two seconds. You can press the emergency key even if the keypad is locked. If you are on an active call, you must end it before pressing the emergency key.

1. From any mode, press and hold **9** until the unit displays “EMERGENCY”. The phone then automatically dials the emergency number.
2. To end the call, press , or close the cover.

---

**NOTE:** Access to 911 may not be available in all areas. For details on the Emergency Dial feature, contact Customer Care at 1-800-639-6111 or dial 611 on your Nextel phone.

---

## Non-Emergency Dial

Now you can call the State Police and Highway Patrol faster, at no charge, when you're on a major highway or turnpike in Nextel coverage areas in localities that offer non-emergency dialing.

Report traffic accidents, motorist problems, careless drivers or any other non-emergency highway incident.

Your Nextel phone is already programmed with the number provided by the State Police and Highway Patrol units operating in the areas where this service is offered.

Check the Nextel website at [www.nextel.com](http://www.nextel.com) for an up-to-date list of current numbers.

---

**NOTE:** Accessibility of non-emergency dialing service within each state is subject to availability along major highways.

---

## Hands-Free Speakerphone

The *i1000plus* provides the convenience of a hands-free speakerphone for holding impromptu meetings or listening to your voice mail messages.

During speakerphone operation, you may either speak or listen, but you cannot do both at the same time.

Speakerphone operation varies according to whether the cover is open or closed.

- If the cover is open during a speakerphone call and you close the cover, you will end the call.
- If the cover is closed during a speakerphone call and you open the cover, the call switches to the earpiece. You can return to speakerphone operation by pressing  under "Spkr".

To use the speakerphone:

1. Press  under "Spkr". The "Spkr" option flashes while the speakerphone is on.
2. Place the phone 15-30 inches (380-760 millimeters) away from you. In a noisy environment, you may want to move the *i1000plus* closer to you for improved audio clarity.

---

**NOTE:** If there is background noise in your area, you may have difficulty hearing a caller's voice or messages. To resolve this problem:

1. To listen only, press  under "Mute". The display changes from "Phone In Use" to "Phone Mute", indicating that the microphone is muted.

While the microphone is muted, you can hear incoming audio, but a caller cannot hear any speech coming from your *i1000plus*.

2. To speak, press  under "Mute" again. The display changes from "Phone Mute" to "Phone In Use", indicating that the microphone is on.
-



## Receiving a Phone Call

When you receive an incoming call indicated by a ring or vibrate, you can answer the call with the cover closed or open.

### Cover Closed

- Press  under “Spkr” to activate the speakerphone.
- Or, open the cover to answer the call using the earpiece.

### Cover Open

- Press , or, press any numeric key (0 through 9).
- Or, press  or .

To activate the speakerphone, press  under “Spkr”.

## Missed Call Indicator

Your *i1000plus* notifies you of unanswered phone calls. If you subscribe to Caller ID, your *i1000plus* temporarily stores the caller’s phone number in your Last 10 Received Calls list. Your screen displays a flashing message with the number of missed calls.

Press any key to clear the flashing indicator.

To retrieve missed calls:

1. Press  until you see the “Calls” option.

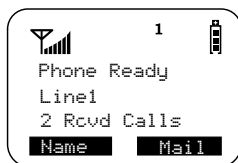

2. Press  under “Calls”. The “Rcvd Calls” screen opens with the number or name of the last call that you received.

**Note:** Time and date will be displayed when Time and Date are available in your area.

3. Use  to continue viewing the list.



## Setting the Ringer Volume

You can adjust the ringer volume for incoming calls. For Alternate Line users, be sure to select the phone line before setting the ringer volume (See “Using an Alternate Line” on page 30.)

1. Press **\*←**, **#**, **3 DEF**, **0 next**. The display shows your current ringer volume.
2. Press **▲** or **▼** on the side of the phone to listen as you raise or lower the volume. If you press **▼** to the lowest setting, the words “Volume Silent” will appear on the phone display.
3. When you determine the desired level, press **●** under “Exit”.



## Selecting a Ring Style

With your i1000plus, you even have a choice on how you'd like to be notified of incoming calls. Your Nextel phone has nine selectable ring styles. Customers with Alternate Line service can use the same ring style or different ring styles for each phone line, so you can tell which line is ringing. Make sure you are on the correct line when selecting a ring style.

1. Press **\*←**, **#**, **3 DEF**, **1..'**.  
The display shows your current ring style.
2. Press **●** under “Ok”.
3. Press **◀▶** to scroll through the available Ring Styles.
4. Press **▲** or **▼** on the side of the phone to listen to the selected ring style.
5. To choose the current Ring Style in the display, press **●** under “Ok”.  
*To leave the Ring Style unchanged, press **●** under “Cancel”.*
6. Press **●** under “Exit”.



## Selecting a Ring Style for the Alternate Line

1. Press **MENU** until you see “Line2”.
2. Press **●** under “Line2”.
3. Repeat the procedure for “Selecting a Ring Style” on page 18.

## VibraCall

VibraCall is a vibration alert system that notifies you of incoming Phone, Private, or Group calls and messages by vibration. You can select this alert system for all incoming calls/messages, or select individual services for VibraCall.

---

**NOTE:** When you set vibration alerts, they are set only for the current line.

If you have a second phone line, you must select “Line 2” and repeat the procedure for selecting all services or selecting individual services to vibrate.

---

The vibration choices are:





- Vibrate Alert: All—produces a vibration alert for all incoming calls and messages.
- Phone Vibrate—produces a vibration alert for incoming phone calls and Nextel Online data calls (see the *Nextel Online Dial-up Services User’s Guide*).
- Phone Vibrate/Ring—produces a vibration alert and a ring tone for incoming phone calls and Nextel Online data calls (see the *Nextel Online Dial-up Services User’s Guide*).
- Mail Vibe—produces a vibration alert for mail messages and net alerts (future availability).
- Group/Prvt Vibe—produces a vibration alert for incoming group and private calls.

---



**NOTE:** If VibraCall is set for all incoming calls and messages, the power-up sequence includes a brief vibrate cycle.

---

### Selecting VibraCall for All Incoming Calls and Messages

1. Press , , , .
2. Press  under “All”. The *i1000plus* will emit a brief vibration.



- After you set VibraCall for all incoming calls and messages, the display returns to the previous mode, and  (the Vibrate All icon) appears at the top of your display.
- The  icon appears on your display to remind you that the audio will be heard through the earpiece instead of the speaker.
- To hear Nextel Direct Connect calls through the speaker, press  on top of the phone.



## Selecting VibraCall Alert for Specific Phone or Mail Services

To set a vibration alert for all or specific phone services:

1. Press , , , ,  wxyz.



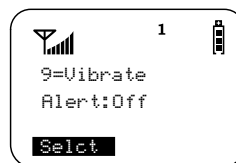

2. Press  until you see the "Selct" menu option.



3. Press  under "Selct". The first selection is Phone Vibrate.



4. To view the Vibe/Ring alert choice (V/Rng), press  on the keypad.

5. To view other choices, press .

- To receive vibration alerts only for Mail, select "Mail Vibe", then select "On".
- To receive vibration alerts for Group and Private calls, select "Group/Prvt", then select "On".

6. Press  under "Exit" to return to the Vibrate Alert menu.



7. Press  under "Exit" again to return to the main menu.

## Creating, Editing and Using Stored Lists

A stored list is made up of Phone Numbers and Private IDs and their related names. Stored lists are convenient because you do not have to remember names and numbers— you simply scroll through your stored list.

---

**NOTES:** Want to use your computer to create stored lists for your *i1000plus*? Nextel's iDEN Organizer is available for programming names, phone numbers, and Nextel Direct Connect Private IDs into your phone.

To order, call Nextel Nextday<sup>SM</sup> Accessories at 1-800-914-3240 or contact your Nextel Authorized Representative.

---

### *Combined Phone Number and Private ID List Programming*

This programming function allows you to program the Phone Number, Private ID with the associated name and speed-dial number in one set of steps. This eliminates the need to program the name twice, separately with the number and the ID.

You can store up to 100 phone numbers in your phone list and up to 100 Private IDs in your Private ID List.

The display holds 12 phone-number characters. If the phone number exceeds 12 characters, you can select “More” to see the remaining characters. To return to the start of the number, select “Numbr”.

---

**NOTE:** To see the name with Caller ID, enter the caller's 10-digit regular phone number (703-555-9999) or their 11-digit Nextel number (1-703-555-9999) in your phone list (see “Caller ID” on page 29).

---

### Storing Names and Numbers

1. Press , , , .
2. Press under “Ok”.



The next screen displays the remaining number of phone numbers and Private IDs that you can store.



Next, the “Enter Name” screen displays.

3. Enter the name that you want to associate with this number and select “Store”. See the example in Table 5.



**Table 5: Entering a Name**

**EXAMPLE**

To store the name “TIM”:

1. Enter “T” by pressing **8 TUV** once. The cursor automatically advances to the next space.
2. Enter “I” by pressing **4 GHI** three times, until “I” appears on the display.
3. Enter “M” by pressing **6 MNO** once.

**TIP:** Press **# FN** to change the case of the letter (lower to upper or upper to lower case). *The default style is upper case.*

4. Enter the phone number and press **END** under “Store”.



*To skip the Phone Number entry, press **END** under “Skip”. You will go directly to the “Enter Prvt ID Number” screen.*



The next screen displays the name that you entered and a flashing speed-dial number where the entry will be stored.

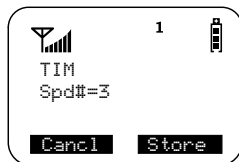





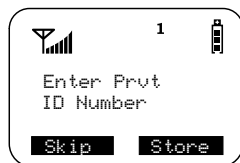







5. Do one of the following:
  - To accept the speed-dial number shown, press **END** under “Store”.
  - To change the speed-dial number, enter the desired speed-dial number. The speed-dial number stops flashing.
  - To cancel the entry and return to the “Enter Phone Number” screen, press **END** under “Cancel”.









6. At the “Enter Prvt ID Number” screen, do one of the following:
  - Enter the person’s Private ID, then press  under “Store”.
  - Or, if you do not wish to enter a Private ID, press  under “Skip”.
7. After you enter all the desired numbers, press  under “Exit”.









## *Editing and Erasing Phone List Entries*

1. Press , , , .
2. Press  under “Ok”. The “Edit Entry?” screen displays.
3. To edit an entry, press  under “Ok”.
  - a. At the “Edit Entry” screen, press  until the desired entry appears, then select “Ok”.
  - b. At the “Edit Number” screen, edit the phone number, if you wish; then select “Store”.
  - c. At the “Edit Name” screen, edit the name, if you wish; then select “Store”.
  - d. At the “Edit Spd#” screen, edit the speed number, if you wish; then select “Store”.
4. To erase an entry at the “Edit Entry” screen, press either  or  once, and then press  under “Ok”.
  - a. Press  to scroll to the desired entry, then press  under “Ok”.
  - b. At the “Erase?” screen, press  under “Yes”.
5. Press  under “Exit” to close the Phone List Edit screen.

## *Editing and Erasing Private ID List Entries*

1. Press , , , .
2. Press  under “Ok”. The “Edit Entry?” screen displays.
3. To edit an entry, press  under “Ok”.
  - a. At the “Edit Entry” screen, press  until the desired entry appears, then select “Ok”.
  - b. At the “Edit ID” screen, edit the number, if you wish; then select “Store”.
  - c. At the “Edit Name” screen, edit the name, if you wish; then select “Store”.



4. To erase an entry at the "Edit Entry" screen, press either  or  once, then press  under "Ok".
  - a. Press  to scroll to the desired entry, then press  under "Ok".
  - b. At the "Erase?" screen, press  under "Yes".
5. Press  under "Exit" to close the Private ID List Edit screen.

## Last 10 Numbers Received/Sent Call List



If you subscribe to Caller ID, you can view, dial, and store the last ten received and last ten sent telephone numbers.

The most recent received or sent call appears first in your call list.

From the Phone Ready screen:



1. Press  until you see the "Calls" menu option.
2. Press  under "Calls". The Rcvd Calls screen opens.



3. To view the entries in the Received Calls list, use  .



- *If the "Store" option appears, the number currently displayed is not in your Phone list. To add the number to your list, press  under "Store".*



4. To view the Sent Calls list, press  until you see the "Sent" menu option. Use   to view each entry.

- *If the "Store" option appears, the number currently displayed is not in your Phone list. To add the number to your list, press  under "Store".*



5. To return to the Received Calls list, press  until you see the "Rcvd" menu option, and then select it.
6. To close the Call list, press  under "Cancel".

## Quickstore of Phone Numbers

Quickstore allows you to quickly store a received or sent phone number without having to enter the programming menu.

When scrolling through the Received or Sent Calls lists, if the name for the received or sent phone number is not already stored in your Phone list, the “Store” option will be available.

---

**NOTE:** As you scroll through the Last 10 Received or Sent Calls list, only the name displays. If the name is not available, the phone number displays.

---

To use Phone Number Quickstore, do one of the following:

1. Go to the last call you dialed by pressing



2. Press under “Store”.

3. Enter the name, then press under “Store”.



To view the Received and Sent Call list:

1. Press until you see “Calls”, then select it.
2. Scroll to the desired phone number.
3. Press under “Store”.
4. Enter the name, then press under “Store”.



**Note:** The name and number entry is stored in the first available storage space.

The Stored message displays with the name that you entered.



## Quickstore of Private IDs

Quickstore allows you to quickly store a received or sent Private ID without having to enter the programming menu.

The ID is added as the last number received or sent in Private mode.

To use Private ID Quickstore, from the Private Ready screen with the Private ID displayed:

1. Press  under "Store".



2. Enter the name associated with the Private ID.



3. Press  under "Store". The Stored message displays with the name that you entered.

*If the list is full with the maximum 100 entries, you will get the message, "Prvt List Full". You cannot add names until you remove some names from the list.*



4. Next, the Prvt Ready screen displays the stored name.



## ADDITIONAL PHONE SERVICES

In addition to making and receiving phone calls in Phone mode, you can use Call Waiting, Call Hold, 3-way Calling, and Call Forwarding.

### Call Waiting



Call Waiting allows you to switch between calls. It is always ON unless you turn it OFF for a specific call.

---



**NOTE:** If your phone is activated with two lines and you select the Call Waiting option for one line, the alternate line is automatically changed.

---

### Answering an Incoming Call Waiting

- If you're already on a call, you will hear a tone to alert you of an incoming call. Your display shows the incoming number and asks "Accept Call?".
  - To accept the call, press  under "Yes".
  - To decline the call, press  under "No". If you're a Nextel Voice Mail customer, the call will be forwarded to your Nextel Voice Mailbox.





- To switch between calls, press , then press  under "Hold". This allows you to move between the two calls.
- To end the active call, press  or close the cover.







### Turning Off Call Waiting

You can turn off Call Waiting if you do not want to be interrupted during a call.

- Press  until you see "Wait", then select "Wait".
- Press  under "Off". Call Waiting will be disabled for one call—but will automatically reset to On after that call.

## Call Hold

When you're already on the phone, you can place a call on hold and make a second call. The options "3way" and "Spkr" appear only when you are on an active call.



1. To place the active call on hold, press , then press  under "Hold". You may then answer or place another call.
2. To toggle between the two calls, press , then press  under "Hold" again.

## 3-Way Calling





Using 3-way calling, you can combine two ongoing phone calls into one conversation. This option is available only when you initiate the second call.

When you place or receive a phone call, a "3way" option appears in the bottom left-hand corner of the display screen.

To make a 3-way call:

1. Place or receive a phone call on either line 1 or 2.
2. Press  under "3way". This places your current call on hold.
3. Enter the phone number for your second call and press .
4. When the second call is connected, select "3way" to join the two calls. Both phone numbers and "3way" appear on your screen.
5. To end the 3-way call, press  or close the cover.

If you are using the speakerphone and want to use 3-way calling:

1. Press .
2. Press  under "3way". This places your call on hold.
3. Enter the phone number for your second call and press .
4. When the second call is connected, select "3way" to join the two calls. Both phone numbers and "3way" appear on your screen.
5. To end the 3-way call, press  or close the cover.

## Call Forwarding

Call Forwarding lets callers reach you wherever you are—incoming calls are forwarded to a designated number. To activate or modify Call Forwarding, you must be in a coverage area (status light is blinking green).

You can select the call forward number from your Phone list using the scroll, name search, or speed dial method. For more information, see "Making Phone Calls" on page 13.

## Turning On Call Forward

1. Press **MENU** until you see “Forwd” on the last line of the display.
2. Press **•** under “Forwd”.

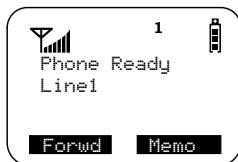

3. To select the number where you want your calls forwarded, do one of the following:
  - Enter a number.
  - Or, press the scroll keys to select a number from your stored list.

*For more information, see “Combined Phone Number and Private ID List Programming” on page 21.*

4. Press **•** under “On”.
5. After the “Please Wait” message displays, press **•** under “Exit”.



Your calls will now be forwarded to the number that you selected and you will see the Call Forward icon  with the forwarded line number on your screen. You can forward Line 1 or Line 2 independently.

## Turning Off Call Forwarding

1. Press **MENU** until you see “Forwd” on the last line of the display.
2. Press **•** under “Forwd”.
3. Press **•** under “Off”.
4. After the “Please Wait” message displays, press **•** under “Exit”.

## Transferring Calls to Voice Mail

If you are a Nextel Voice Mail subscriber, this feature allows you to transfer incoming calls directly to Voice Mail with just the touch of a button. Simply press **•** under “End” on your Nextel phone while it is ringing and the call will be transferred to your Voice Mail.

If you have not yet subscribed to Nextel’s Voice Mail service, you can do so by calling Nextel Customer Care at 1-800-639-6111.

## Caller ID

With Caller ID, your *i1000plus* automatically displays the phone number and/or name of the person calling unless it was blocked by the caller.

Caller ID allows you to decide whether to take a call right away or let it forward to Voice Mail. To enable forwarding to Voice Mail, the purchase of Nextel Voice Mail is required.

*Caller ID is not available in all areas.*

## ***Display Caller's Name***

A caller's name will be displayed on your Nextel phone only if you previously programmed it in your phone list with the caller's 10-digit regular phone number (703-555-9999) or the caller's 11-digit Nextel number (1-703-555-9999). *For more information, see "Combined Phone Number and Private ID List Programming" on page 21.*

## ***Maintaining Your Privacy with Per-Call and Per-Line Blocking***

Nextel provides two no-charge methods to prevent those you call from seeing your number on their own Caller ID displays.

Your Nextel phone number cannot be blocked from calls made to 911, 800, 877, 888, or 900 phone numbers.

### **Per-Call Blocking**

Per-Call Blocking lets you selectively block delivery of your phone number to other Caller ID units. Activate free Per-Call Blocking by dialing \*67 before dialing the call. Per-Call Blocking is released when the call is ended.

### **Per-Line Blocking**

Per-Line Blocking lets you permanently block delivery of your phone number on every call you make. You can disable this feature on a per-call basis by dialing \*82 before the call. You must order this feature from Nextel. To get your company's line automatically blocked on every call, contact Nextel Customer Care at 1-800-639-6111.

## **Using an Alternate Line**

The *i1000plus* also allows you to have an alternate line. You can designate your alternate line as a "priority line" or you can use it to separate business and personal calls. If you are an alternate line customer, you will be given a unique phone number for each line.

1. If your Nextel phone is activated with two lines, you have the following options:
  - Different pricing by line
  - Distinct billing records to track usage
  - Separate address billing for additional line, for example, home billing
2. The following settings are independent for each phone line. When you enable a setting, it applies only to the active line.
  - Ringer Volume
  - Selectable Ring Styles
  - Call Forwarding
  - One-minute Beep
  - Automatic Display Timer
  - Resettable Timer
  - Total Call Timer

- The alternate line does not have all the features of the first line:
  - Line 2 shares the voice mailbox with Line 1; there is only one monthly charge.
  - You cannot forward Line 2 to Line 1 and have the phone ring; the call defaults to Voice Mail.
  - Text and Numeric Paging is not offered on Line 2.
  - A call from line 2 will appear on the recipient's Caller ID as the Line 1 phone number.

### Selecting the Alternate Line

At the "Phone Ready" screen:

- Press **MENU** until you see "Line2". (If you are on Line 2, you will see "Line1".)
- Do one of the following:
  - Press **0** under "Line2" to activate Line 2 when Line 1 is the active line.
  - Or, press **0** under "Line1" to activate Line 1 when Line 2 is the active line.

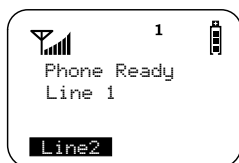

### Receiving a Call

You can receive calls on either line, regardless of the active line setting.

- If the call is on the same line as the currently active line, the active line icon simply flashes.
- If the call is on the line that is not currently active, the active line icon remains lit and the additional line icon flashes.

### Receiving Calls on Your Alternate Line

If you are on a call on one line:

- Press **0** under "Yes" to answer the call on the other line. Your original call will be placed on hold.
- You can do one of the following to the active line:
  - To end the call, press **0**. You will automatically revert to the original call.
  - Or, to place the current call on hold, press **MENU**, then press **0** under "Hold".
  - To toggle between the two calls, press **MENU**, then press **0** under "Hold" again.

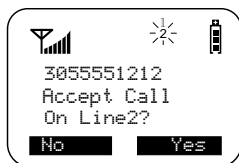



When both calls end, the phone remains active in the last line selected.

## NEXTEL VOICE MAIL

Welcome to Nextel Voice Mail. Your Nextel *i1000plus* offers a powerful and easy-to-use Voice Mail service. It can take messages when you're away from your phone, your phone is turned off, you're on another call, or you are out of the Nextel coverage area.

### Setting Up Your Voice Mailbox for the First Time

#### From a regular phone:

1. Dial your Nextel Personal Telephone Number (PTN).
2. A greeting will play. During the greeting, press the   key.
3. The system will prompt you to "Please enter your password".
  - Enter the last seven digits of your Nextel phone number. This is your temporary password.
4. Follow along with the tutorial to:
  - Create a 4- to 7-digit password.
  - Record your name.
  - Record a greeting.

#### From a Nextel phone:

1. Dial your Nextel Personal Telephone Number (PTN).
2. The system will prompt you to "Please enter your password".
  - Enter the last seven digits of your Nextel phone number. This is your temporary password.
3. Follow along with the tutorial to:
  - Create a 4- to 7-digit password.
  - Record your name.
  - Record a greeting.

Be sure to listen all the way through the tutorial to the point that you hear the system say, "Enjoy using Nextel Voice Mail". Your mailbox set-up is complete.

## Sample Greetings

- For Voice Messages Only

Hello, you've reached \_\_\_\_\_. I'm sorry I missed your call. If you leave a message at the tone, I'll return your call as soon as possible. If you would like to bypass this greeting in the future, press pound. Thank you for calling.

- For Voice and Numeric Messages

Hello, you've reached \_\_\_\_\_. I'm sorry I missed your call. To leave a numeric page, press 1. To leave a voice mail message, wait for the tone and then record your message. I'll return your call as soon as possible. If you would like to bypass this greeting in the future, press pound. Thank you for calling.

- For Voice, Numeric and Operator Assisted Messages

The following message option is available only to subscribers with Operator Assisted Paging.

Hello, you've reached \_\_\_\_\_. I'm sorry I missed your call. To leave a numeric page, press 1. To leave a text page, press 2. To leave a voice message, please wait for the tone and then record your message. I'll return your call as soon as possible. If you would like to bypass this greeting in the future, press pound. Thank you for calling.

*For more information about text and numeric paging, see "Using Text and Numeric Paging" on page 50.*

## Accessing the Voice Mail Service After Set Up

To access the Voice Mail service from a regular phone, follow the dialing instructions under "Setting Up Your Voice Mailbox for the First Time" on page 32.



---

**NOTE:** To access your messages from your Nextel phone, you must have received at least one Voice Mail message.



**TIP:** You can dial your Nextel number and leave yourself a message.

---

To access the service from your Nextel Phone:

1. Press  under "Mail". The mailbox opens.
2. Scroll to the desired mail option, such as Voice Mail, by using  or Volume/List Control buttons, or press the corresponding numeric key, for example, 1.



- Press  under "Ok". The Voice Mail inbox opens. The number of new and total messages in your Voice Mailbox is displayed.
- Press  under "Dial" to dial your voice mailbox.

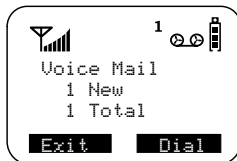

## Receiving New Voice Mail Messages





Your Nextel Phone alerts you when you receive a new Voice Mail message.

### Voice Mail Notification



When you receive a new Voice Mail message, your Nextel Phone:

- Displays "New Voice Mail Waiting" on the screen (urgent messages will say "Urgent").
- Flashes the  icon at the top of your screen.
- Issues a mail alert ring, every 30 seconds.

To turn your Voice Mail display on or off:

- Press , , , .
- Press  under "Ok".





- Press  to scroll to the desired service for display.
- Use the volume control buttons on the left side of your phone to increase or decrease the volume or turn it OFF completely.
- Press  under "Exit".
- Press  under "Exit" again.



## Viewing Voice Mail Message Status in Your Mailbox

To see the number of messages in your voice mailbox at any time:

- Press  under "Mail". The mailbox opens.
- Scroll to the desired mail option, such as Voice Mail, by using  or Volume/List Control buttons, or press the corresponding numeric key, for example, 1.



3. Press **OK** under “Ok”. The Voice Mail inbox opens.

The screen indicates the total number of messages in your box, as well as the number of new messages. An exclamation point (!) indicates that at least one of the new messages is urgent.

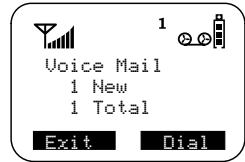

4. To close your voice mailbox, press **EXIT** under “Exit”.

## Listening to New Messages

When you receive a new message, you can listen to it immediately or wait until later.

To listen to the message now:

1. Press **DIAL** under “Dial”.
2. When prompted, enter your password. The service will now guide you through your messages.

To listen to the message later:

- Press **EXIT** under “Exit”. This clears the display. The **NEW** icon stops flashing, but remains on the screen to remind you that you have a new message.

**Note:** The New Message icon **NEW** can appear while you are on a call. If this happens, follow the steps outlined in the above section.

## Saving and Deleting Messages

Note: You may save or delete a message while the message is still playing. If you do not save or delete the message, it remains a new message in your mailbox for 30 days and will then be deleted.

After you listen to a message:

- Press **7 PQRS** to delete the message.

To retrieve a message after you delete it, press **\* LEFT**, **3 DEF**. This will recover ALL deleted messages.

**Important!** You can recover only the messages that you deleted during your current Voice Mail session. **After you exit the session, you cannot recover a deleted message.**

- Press **9 WXYZ** to save the message.

## Nextel Voice Mail Features

When you log into the Voice Mail service, you will be at the Main Menu. This is the starting point for any function you want to perform within the Voice Mail service. You can access additional features through various sub-menus described in this guide. You can return to the Main Menu at any time by pressing **\*←**, **#**.

## Playing Messages

When you enter your mailbox, the Voice Mail service tells you how many messages you have and whether they are new, saved or in preparation.

Your messages will play in the following order:

- Urgent.
- New (unheard and heard).
- Saved.
- Message in preparation (an outgoing message you are preparing to send to another party or to a group list).

For example, you may hear:

“You have four messages. One is new, two are saved and one is in preparation.”

## Listening to Messages

1. Log into Voice Mail. See “Accessing the Voice Mail Service After Set Up” on page 33.
2. Press **1** to listen to your messages.

### Listening Options Quick List

While listening to your messages, you can:

- Press **1** to replay the previous six seconds.
- Press **1**, **1** to rewind to the beginning of the message.
- Press **2** to pause/continue the current message.
- Press **3** to fast forward six seconds.
- Press **3**, **3** to fast forward to the end of the message.

During or after a message is played, you can:

- Press **6** to copy a message to another subscriber. See “Acceptable Destination Addresses” on page 38.
- Press **7** to delete a message.



- Press **8 TUV** to reply to a message. See “Acceptable Destination Addresses” on page 38.
- Press **9 WXYZ** to save the message.
- Press **#**  to skip to the next message.
- Press **\* <**, **3 DEF** to recover all deleted messages in that session.

---

**NOTE:** If you do not save or delete a message, it remains in your mailbox for 30 days as a “new” message. Both saved and unsaved messages are automatically deleted from the system after 30 days.

---

### *Helpful Hints*

- Press **1 .-'**, **1 .-'** to play new unheard messages only.
- Press **#**  , **#**  to play saved messages.
- Press **5 JK L**, **5 JK L** to play the date and time stamp for a message (at any time during the message).

### *Choosing the Order of Messages Played*

You can play your messages:

- From the last one received to the first one received (Last In/First Out—LIFO).
- Or, from the first one received to the last one received (First In/First Out—FIFO)

To choose between Last In/First Out and First In/First Out:

1. Log into Voice Mail. See “Accessing the Voice Mail Service After Set Up” on page 33.
2. Press **4 GHI** to reach the Personal Options Menu.
3. Press **4 GHI** to reach Personal Preferences.
4. Press **2 ABC** to reach Playback Preferences.
5. Press **1 .-'** to toggle between LIFO and FIFO.

## Normal or Automatic Playback

You can navigate through the Play Menu:

- Using the default Normal Playback, which means entering every key as the service prompts you, as described in “Listening to Messages” on page 36.
- Or, you can use Automatic Playback, which lets you enter your mailbox and listen to your messages automatically. If you choose Automatic Playback, messages are automatically saved.

To activate or deactivate Automatic Playback:

1. Log into Voice Mail. See “Accessing the Voice Mail Service After Set Up” on page 33.
2. Press **4 GHI** to reach the Personal Options Menu.
3. Press **4 GHI** to reach Personal Preferences.
4. Press **2 ABC** to reach Playback Preferences.
5. Press **2 ABC** to toggle between Normal and Automatic Playback.

## Sending Messages

### Acceptable Destination Addresses

This function allows you to record and send a message. You can send the message to a mailbox number, a name in the Voice Mail service directory or a Group List number.

When you send, reply to, or copy a message, you must assign a destination address before the service can deliver the message.

The following options are available when assigning destination addresses to your message:

- **Mailbox Numbers**

You may enter the mailbox number (10-digit telephone number) of a service subscriber. When you enter the mailbox number, the name response of the recipient plays if it is recorded.

- **Group Lists**

You may enter a one- or two-digit Group List Number. You must have previously created the list. See “Group Lists” on page 43.

- **Address by Name**

You may use the Address by Name feature to send your message to another Voice Mail user on your account. Press **0 next** followed by the first few letters of the subscriber's last name. If more than one subscriber has the same last name, enter the complete last name followed by **0 next** and the first few digits of the subscriber's first name.

## Recording and Sending Messages

1. Log into Voice Mail. See “Accessing the Voice Mail Service After Set Up” on page 33.
2. Press **2 ABC** to begin recording your message.
3. Record your message. When you finish, press **#** . The system will ask you to press **9 WXYZ** to address the message or for special delivery options, press **5 JKL** .
4. Press **9 WXYZ** to address the message.
5. You may enter one or more of the following to assign destination addresses to your message:
  - Mailbox Number
  - Group List Number
  - 0 + last name; 0 + first name
6. After you have entered all of the addresses, press **#** to send the message.

## Special Delivery Options

Special delivery options can be added when sending, replying to, or copying a message.

- Press **1 .,\*** for urgent delivery.
- Press **2 ABC** for private delivery.
- Press **3 DEF** for notification of non-delivery.
- Press **4 GHI** for future delivery.

After making your selection:

- Press **9 WXYZ** to address the message.
- For addressing information, refer to Step 5 under “Recording and Sending Messages”.
- When you have entered all of the addresses, press **#** to send the message.

## ***Urgent***

When you mark messages as urgent, the recipient will hear it before other messages in the mailbox.

1. Press **5** JKL for delivery options.
2. Press **1** ,-' for urgent delivery.
3. Press **9** WXYZ to address the message.
  - For addressing information, refer to Step 5 under “Recording and Sending Messages”.
4. When you have entered all of the addresses, press **#** ☰ to send the messages.

## ***Private Delivery***

When you mark a message as private, the recipient cannot copy it to another mailbox or phone number.

1. Press **5** JKL for delivery options.
2. Press **2** ABC for private delivery.
3. Press **9** WXYZ to address the message.
  - For addressing information, refer to Step 5 under “Recording and Sending Messages”.
4. When you have entered all of the addresses, press **#** ☰ to send the message.

## ***Notification of Non-delivery***

This feature allows you to be notified when a recipient has not listened to your message by a certain date and time.

1. Press **5** JKL for delivery options.
2. Press **3** DEF . At the prompt, enter the date and the time you want to be notified of non-delivery.
  - Sample date - October 5 = 1005
  - Sample time - 1:00pm = 1300
3. Press **9** WXYZ to address the message.
  - For addressing information, refer to Step 5 under “Recording and Sending Messages”.
4. When you have entered all of the addresses, press **#** ☰ to send the message.

## *Future Delivery of Messages*

This feature allows you to deliver a message at a specified future time and date.

After recording a message:

1. Press **5** JKL for delivery options.
2. Press **4** GHI . At the prompt, enter the date and the time you want your message sent. You can stamp future dates up to three months in the future.

Sample date - October 5 = 1005

Sample time - 1:00pm = 1300

3. Press **9** WXYZ to address the message.
  - For addressing information, refer to Step 5 under “Recording and Sending Messages”.
4. When you have entered all of the addresses, press **#** 0 to send the message.

**IMPORTANT:** Once a message has been sent for future delivery, it cannot be retrieved or deleted.

## **Greetings**

### *Recording a Personal Greeting*

Your personal greeting will be played to callers when they reach your Voice Mailbox.

To record a greeting:

1. Log into Voice Mail. See “Accessing the Voice Mail Service After Set Up” on page 33.
2. Press **3** DEF to reach the Greetings Menu.
3. Press **2** ABC to record your greeting.
4. Record your greeting and press **#** 0 .

## Playing Back/Deleting Your Greeting

You can listen to your greeting after you are finished recording it. If you do not want to record your own greeting, Nextel Voice Mail provides a generic greeting. If you have already recorded a personal greeting, you must delete it before the generic greeting will play.

To play or delete your greeting:

1. Log into Voice Mail. See “Accessing the Voice Mail Service After Set Up” on page 33.
2. Press **3 DEF** to reach the Greetings Menu.
3. Press **1 . . .** to play your active greeting.
4. Press **7 PGRS** to delete your greeting.

Note: Your active greeting is the greeting currently playing to callers.

## Greetings Schedule (Optional)

Nextel Voice Mail service lets you record up to 4 separate greetings that are played based on time of day/day of week. For example, your morning greeting can include “good morning” in your greeting. If you are traveling, you can set up a special greeting that lets callers know how long you will be away.

To set up multiple greetings, you must:

1. Turn ON the Greetings Schedule function.
2. Record at least 3 greetings.

When you subscribe to Nextel Voice Mail, the greeting schedule is already set up with designated time periods for each of the four greeting slots. They are:

- Greeting 1: Generic Greeting  
24 hours a day; seven days a week if you have not activated your Greeting Schedule
- Greeting 2: Morning Greeting  
8:00am - 11:59am; Monday through Friday
- Greeting 3: Afternoon Greeting  
12:00pm - 5:00pm; Monday through Friday
- Greeting 5: Travel Greeting  
24 hours a day, Seven days a week

## Recording Multiple Greetings

To record your four greetings:

1. Log into Voice Mail. See “Accessing the Voice Mail Service After Set Up” on page 33.

2. Press **3 DEF** to reach the Greetings Menu.
3. Press **4 GHI** to record a selected greeting number.

Enter the greeting number you wish to modify. After you have entered the greeting number, you can do the following:

- Press **1 .\*** to play the greeting currently recorded in this slot. The Voice Mail service will alert you if a greeting has not been recorded.
- Press **2 ABC** to record a greeting.
- Press **7 PQRS** to delete a greeting that is already recorded in this slot.
- Press **\* 1** to go back to the Greetings Menu so that you can record another greeting number.

### Activating Your Greeting Schedule

This feature lets you activate your greeting schedule so that the Voice Mail service will automatically play the greetings you have recorded in greeting slots number 2 and 3.

To turn your greeting schedule ON or OFF:

1. Log into Voice Mail. See “Accessing the Voice Mail Service After Set Up” on page 33.
2. Press **3 DEF** for the Greetings Menu.
  - Press **9 WXYZ** to activate or deactivate your greeting schedule.
  - Press **8 TUV** to listen to your greeting schedule.

## Group Lists

A group list is a group of mailboxes assigned a number and a recorded name. Once you have created one or more lists you can send a message to everyone on the list by simply entering the group list number. You can have up to 40 group lists and each list can have up to 50 addresses.

### Setting up Group Lists

1. Log into Voice Mail. See “Accessing the Voice Mail Service After Set Up” on page 33.
2. Press **4 GHI** to reach the Personal Options Menu.
3. Press **2 ABC** for group list options.
4. Press **2 ABC** to create a group list.
5. Enter the one- or two-digit group list number, then press **# m**.

6. Record a name for the list, then press **#** **☰** .
7. Enter any or all of the following types of destination addresses:
  - Mailbox Number
  - Group List Number
  - 0 + last name; 0 + first name

Press **#** **☰** after each entry is made.

8. Press **#** **☰** to save all entries added to the list.

### ***Reviewing/Deleting/Adding to a Group List***

1. Log into Voice Mail. See “Accessing the Voice Mail Service After Set Up” on page 33.
2. Press **4** **GHI** to reach the Personal Options Menu.
3. Press **2** **ABC** for group list options.
4. Press **1** **.,'** to review your group list directory.
5. Press **3** **DEF** to delete a group list. Enter the one- or two-digit group list number that you wish to delete.
6. Press **4** **GHI** to modify a list. Enter the list number, then press **#** **☰** .
7. Press **1** **.,'** to add an address to the list.

### ***Reviewing/Changing Group List Names and Numbers***

1. Log into Voice Mail. See “Accessing the Voice Mail Service After Set Up” on page 33.
2. Press **4** **GHI** to reach the Personal Options Menu.
3. Press **2** **ABC** for group list options.
  - Press **4** **GHI** to modify a list. Enter the list number, then press **#** **☰** .
  - Press **2** **ABC** to review addresses on the list or
  - Press **3** **DEF** to play the list name or
  - Press **4** **GHI** to re-record a name for your group list.
  - Record your list name, then press **#** **☰** .

## Pager Notification

The Voice Mail service has the ability to notify your pager when you have received a message. If you would like to activate this feature, you must enable pager notification. Please call Nextel Customer Care at 1-800-639-6111 to activate this feature, or dial 611 from your Nextel phone.

### *Enabling Pager Notification*

This feature allows you to enable or disable your pager notification and confirm the pager number to which your messages are being sent.

1. Log into Voice Mail. See “Accessing the Voice Mail Service After Set Up” on page 33.
2. Press **4** GHI to reach the Personal Options Menu.
3. Press **3** DEF to reach the Pager Notification options.
  - Press **3** DEF to enable/disable pager notification.
  - Press **4** GHI to enable/disable notification on urgent messages only.
  - Press **1** .,-' to play your pager number.

### *Limiting Notification to Specific Times*

You can choose certain times of the day to be notified of new messages. For example, you could select to be notified between 8:00am and 5:00pm only. In this example, if someone sends you a message at 5:15pm, you will not be notified of that new message until the next day at 8:00am. If you do not specify a time period to be notified of new mail, you will be notified at all hours.

To specify the times you want to be notified:

1. Log into Voice Mail. See “Accessing the Voice Mail Service After Set Up” on page 33.
2. Press **4** GHI to reach the Personal Options Menu.
3. Press **3** DEF to reach the Pager Notification options.
4. Press **5** JKL to modify your notification time window.

You will be asked to enter the starting time and the ending time for your time window. For acceptable time of day and day of week entries see “Voice Mail Time and Dates” on page 48.

## Personal Password and Name Response Options

### *Changing your Password*

Once you change your password from the initial password to your own personal password, nobody else can enter your mailbox except you. Passwords must be 4 to 7 digits long. You should choose a combination of letters or numbers that you can remember easily and only you will know.

1. Log into Voice Mail. See “Accessing the Voice Mail Service After Set Up” on page 33.
2. Press **4 GHI** to reach the Personal Options Menu.
3. Press **4 GHI** to reach Personal Preferences.
4. Press **1 .\*** to change your password.
5. Enter a 4- to 7-digit password.
6. Press **#** .

### *Name Response Options*

Your name response is a recording of your name only, without a greeting. It serves as the identification tag for your mailbox. When you send, reply to, or copy a message, your name response will precede your message. Your name response will also play as a confirmation when someone else is sending you a message or adding your mailbox number to their Group List.

Recording/Playing/Deleting Your Name Response:

1. Log into Voice Mail. See “Accessing the Voice Mail Service After Set Up” on page 33.
2. Press **4 GHI** to reach the Personal Options Menu.
3. Press **4 GHI** to reach Personal Preferences.
4. Press **3 DEF** to reach Name Options.
  - Press **1 .\*** to play your name response.
  - Press **2 ABC** to record your name response.
  - Press **3 DEF** to delete your name response.

## Message Forwarding

This feature allows you to program your phone to automatically forward incoming Voice Mail messages to another mailbox. Message Forwarding insures your messages get attention when you are not available.

To use Message Forwarding you must:

- Program a forwarding address into your mailbox.
- Enable the forwarding feature.
- Select a type of message forwarding.

There are two types of message forwarding:

- *Immediate Forwarding* -- The caller is notified that the message being left will be forwarded.
- *Silent Forwarding* -- The caller hears your personal greeting and is not notified that the message is being forwarded.

## Setting Up Message Forwarding

This feature allows you to set up and listen to your current forwarding number.

To set up a forwarding number:

1. Log into Voice Mail. See “Accessing the Voice Mail Service After Set Up” on page 33.
2. Press **4 GHI** to reach the Personal Options Menu.
3. Press **5 JKL** to modify forwarding options.
  - Press **1 .-\*** to hear your current message forwarding number.
  - Press **2 ABC** to add an initial forwarding number or to change your number.
  - Press **3 DEF** to enable/disable message forwarding.
  - Press **4 GHI** to choose your forwarding type:
    - Press **1 .-\*** to select immediate forwarding.
    - Press **2 ABC** to select silent forwarding.

## Caller Options

Your callers have several options when calling you. You can let them know about these options by recording any of the following on your greeting.

- If you would like to leave a numeric page, press **1 .-\***.
- If you would like to send a text message, press **2 ABC**. If your message is urgent, press **5 JKL**. *This option is available only to subscribers with Operator Assisted Paging.*
- To skip this greeting and record a message immediately, press **# m**.

## Voice Mail Time and Dates

The Voice Mail service uses a 24-hour clock (military time), as follows:

**Table 6: Military Times**

Hour	24-Hour Time
12:00 a.m.	0000
1:00 a.m.	0100
2:00 a.m.	0200
3:00 a.m.	0300
4:00 a.m.	0400
5:00 a.m.	0500
6:00 a.m.	0600
7:00 a.m.	0700
8:00 a.m.	0800
9:00 a.m.	0900
10:00 a.m.	1000
11:00 a.m.	1100
12:00 p.m.	1200
1:00 p.m.	1300
2:00 p.m.	1400
3:00 p.m.	1500
4:00 p.m.	1600
5:00 p.m.	1700
6:00 p.m.	1800
7:00 p.m.	1900
8:00 p.m.	2000
9:00 p.m.	2100
10:00 p.m.	2200
11:00 p.m.	2300

---

**NOTE:** To compute the 24-hour clock, add 1200 to the a.m. time to get the p.m. time. For example, adding 1200 to 0200 (2:00 a.m.) gives you 1400 (2:00 p.m.)

Or, subtract 1200 from the p.m. time to get the a.m. time. For example, subtracting 1200 from 1800 (6:00 p.m.) gives you 0600 (6:00 a.m.)

---

**Dates**

All dates must have 4 digits in the MM/DD format: 2 digits for the month and 2 digits for the date.

January is 01, February is 02, and so forth. The first day of the month is 01, the second day of the month is 02, and so forth. For example, January 15 is 0115.

**Day of the Week**

When you program schedules in the Voice Mail service, you must enter the starting and ending days of the week. Enter Sunday as 1, Monday as 2, and so forth.

## USING TEXT AND NUMERIC PAGING

Your new Nextel Phone offers Text and Numeric Paging allowing callers to send you a numeric or text page in an instant. The text or numeric pages are then displayed directly on your phone. You'll quickly find Nextel Text and Numeric Paging service convenient and easy to use.

Nextel Text and Numeric Paging helps keep you in touch with co-workers and customers, regardless of where you travel on the Nextel National Network. Whether it's your office calling with a last minute schedule change, or a customer trying to reach you with an important question, you'll be able to retrieve and respond to pages immediately, all from your Nextel phone.

### The Nextel Paging Advantage

Nextel Text and Numeric Paging service gives you all the advantages of a pager and more. Nextel Paging will accept your pages even if you are unavailable, your phone is turned off, or if you are busy on another call. If you receive a page while outside your coverage area (for example, if you are on an airplane), Nextel will store the page and deliver it as soon as you come back into coverage.

### Page Delivery

Nextel delivers pages for up to five days. Whether you are sending or receiving a page, Nextel will continuously attempt to deliver the page until successful. You can easily retrieve and respond to pages anywhere you travel on the Nextel National Network.

### How to Use Nextel Text and Numeric Paging

Your Nextel Phone refers to text and numeric pages as Message Mail. Pages are stamped with the time and date the page was left. Your phone can store up to 16 pages at one time.

#### *To Send a Page*

Your callers can send numeric pages up to 20 characters in length and text pages up to 140 characters in length, right to your Nextel phone. You can also send a text message from any personal computer that has access to the Internet via the Nextel home page or e-mail.

Callers can quickly and easily leave a numeric or text page in one of the following ways:

- Directly from any phone – by pressing **1** during your voice mail greeting, callers can leave a numeric page.\*
- Through a Nextel operator – by pressing **2** during your voice mail greeting. A Nextel operator will forward the numeric or text page to your Nextel phone.\*\*

- Calling 1-800-NEXGRAM (1-800-639-4726)\*\* — A Nextel operator will forward the numeric or text page to your Nextel phone.
- From a personal computer — by using Nextel NexNote™ software, simply select a recipient, type the message and click the “**Send**” button.
- Web Paging — simply go to the Nextel home page at [www.nextel.com](http://www.nextel.com) and click “**Send a Page**”. Then address your message to your business associate's or friend's 10-digit Nextel phone number. For example: type in 7035551234. Then type your message in the message box and click “**Send**”. The only limit is 140 characters. You can also send a group page to up to six Nextel users at one time.
- E-mail Paging — Simply address your e-mail message to your business associate's or friend's 10-digit Nextel phone number followed by [@page.nextel.com](mailto:@page.nextel.com) (for example: 7035551234@page.nextel.com). Again, the only limit is 140 characters.

\*Be sure to instruct your callers to do this when you record your greeting. See Voice Mail section on “Greetings” on page 41.

\*\*This option is available only to Nextel customers who have subscribed to Operator Assisted Paging. For additional information on how you can sign up for this service, call Nextel Customer Care at 1-800-639-6111.

### Checking Message Delivery

Nextel offers three different ways to confirm if your message was delivered. Simply go back to the Nextel Web site at [www.nextel.com](http://www.nextel.com) and choose one of the following three options:

- Click on the “**Message Status**” button and the system will track your message and report back to you on the delivery status of your page.
- Or, record the claim number when you send your page. Later go back to the Nextel Web site, click on the “**Message Status**” Web link, enter your claim number and the Nextel phone number of the person you paged. Once again, Nextel will track your message and report back to you on the delivery status of your page.
- Or, on the Nextel Web site, when you send your message, enter the e-mail address in the “**E-mail Confirmation**” space. A reply message will be sent to you letting you know that your message was indeed delivered.

## Notification of New Text and Numeric Pages

Your Nextel phone will alert you when you have a new text or numeric page, even if you are on another call. If you are using Nextel Direct Connect, your page will be held and delivered upon completion of your call.

Remember, your Nextel phone refers to text and numeric pages as "Message Mail." When you receive a new page, your i1000plus will:

1. Display "New Mail Read?" on the screen.
2. Flash the  icon at the top of your screen.
3. Issue a mail alert ring every 30 seconds.



## Retrieving New Pages

As soon as you are notified that you have a new page, you can either view the page immediately or wait until later.

### To view the page now:

1. Press  under "Now". The screen will briefly display the number of new and saved pages. Then your first page will appear on the screen.



2. Press  under "Read" to view the page. If it fills more than one screen, use the volume control keys to scroll. You now have the option to either erase or save the page you have just viewed.



3. To erase the page, press  under "Erase". If you have other pages, they will now appear. If you have no other pages, the screen will briefly read "No Mail" and return to the "Phone Ready" screen.





4. To save the page, press  under "Save". If you have other pages, they will now appear. At the conclusion of your pages, you have the option to Exit or Read. "Exit" will return you to the "Phone Ready" screen, while "Read" will return you to your pages.

---

**NOTE:** Pages that are not deleted will remain in your mailbox until you choose to delete them. Your Nextel phone can store up to 16 pages.

---

**To view the page later:**

Press  under “Later”. This will clear the display, the message will disappear and the  icon will stop flashing, but it will remain on the screen to remind you that you have a new message.

***Viewing Your Text and Numeric Pages Status***

Your Nextel Phone lets you view the status of your Text and Numeric Pages in your mailbox at any time by letting you see how many new and saved pages you have.

**To view your page status:**

1. Open the cover and from the Phone Ready screen, select “Mail”. The inbox opens.
2. Scroll to “Mesg Mail” or press the corresponding number.
3. Press  under “Ok”. The screen will briefly display the number of new and saved pages.
4. To view individual messages, see “Retrieving New Pages” on page 52.

**Auto Call Back**

By simply pressing  while viewing a page, your Nextel Phone automatically dials the number that appears on your screen, even if the number is included in the middle of a text page. This allows you to respond immediately to important pages without having to remember the caller’s number or fumble around for a pen and paper to write it down.

Note: If the page you received contains two numbers, Auto Call Back will dial the last number.

***Mail Memory Full***

If all 16 message registers are full, your phone displays the message “Mail Waiting, Memory Full”. You cannot receive new Message Mail until you empty the register space by erasing saved or unread messages.

***NexNote™—A Powerful Personal Computer Connection***

Nextel NexNote software lets you compose and send a page to a Nextel customer right from your personal computer.

Nextel NexNote Plus™ software lets you compose and send a page to several Nextel customers. Simply type your message and it will be delivered to a group of subscribers you select.

NexNote and NexNote Plus software are available in Windows™, Macintosh™, and DOS™ (Basic only) formats.

NexNote tracks your text and numeric pages and lets you know if the page was received by the customer's Nextel phone. If the Nextel customer's phone was not available, NexNote will notify you that the page is being stored for future delivery. Whether you're trying to confirm a meeting time change, reroute a driver's delivery schedule or send new pricing information to an important client, you'll have peace of mind knowing the page was received.

### ***Ordering Nextel Paging Features***

**To order Paging Features,  
call Nextel Customer Care at 1-800-639-6111,  
or dial 611 on your Nextel phone.**

**To order NexNote paging software, call  
Nextel Nextday<sup>SM</sup> Accessories at 1-800-914-3240  
or contact your Nextel Authorized  
Representative.**

## NEXTEL DIRECT CONNECT

Nextel Direct Connect<sup>SM</sup> is a revolutionary way to communicate with your co-workers and clients...for a fraction of the cost of traditional cellular calls.

You may want to talk to a co-worker right away, but you don't want to page that person or leave a lengthy message. With Nextel Direct Connect's Private Call feature, you can find them wherever they are.









Or maybe you need to communicate a last-minute schedule change to your sales people...all 100 of them. It's easy with Nextel Direct Connect's Group Call. This 2-way feature lets you contact all of them at once!

In addition, Nextel has created Nextel Business Networks, which allows you to communicate with individuals outside as well as inside your company. These Networks link Nextel customers in similar industries or geographies. So, if you often need to reach a client, vendor, or contractor instantly, work smarter by joining the Nextel Business Network. For more information, call 1-888-NEXTEL2 (1-888-639-8352).





### Programming Your Own Private ID

Before you get started using Direct Connect, you will want to store your Private ID for future reference.

To store your *i1000plus* Private ID:

1. Press     .
2. Press  under "Ok".
3. Enter your own Private ID, which is given to you at time of activation.
4. Press  under "Store".
5. Press  under "Exit".

---



**NOTE:** If you forget your Private ID after it is programmed, you can recall it by pressing     .

---

### Nextel Direct Connect Private/Group Speaker

Your *i1000plus* acts like a phone or speakerphone with Nextel Direct Connect. If the Private/Group speaker is set ON, all incoming audio will be heard through the speaker. This is helpful in monitoring group activity.

If the Private/Group speaker is OFF, a brief alert tone will notify you of Private or Group call activity. Incoming audio will be heard through the earpiece, allowing you to have private conversations.

Press  on top of the *i1000plus* to turn the Private/Group Speaker on or off. The Private/Group icon  on your display indicates that the Private/Group speaker is OFF and audio will be heard through the earpiece.

## Private Calls

A Private Call is a one-to-one conversation between you and someone else on another Nextel phone. You'll want to make a Private Call if you need to talk to someone in your local calling area and don't want to page or call that person or leave a message that might not be retrieved for hours.

You can make a Private Call with the cover closed or open.

## Making Private Calls

### Cover Closed

To contact the last Private ID that you called:

1. Press **Mode** until you see "Prvt Ready" on your display.
2. Press the PTT button.

To select a number from your Private ID list:

1. Press **•** under "List".
2. Use the Volume Control buttons to scroll to the desired name.
3. Press the PTT button.

### Cover Open

With the cover open, you can use one of the following methods: Direct Entry, Scroll, or Name Method. The Scroll and Name methods require that you have established a Private Call Calling List in your phone.

### Direct Entry

From the "Prvt Ready" mode:

1. Use the keypad to enter the Private ID of the person that you want to reach.
2. To speak, press and hold the PTT button, wait for the chirp, then speak into the microphone.
3. To listen, release the PTT button.





### Scroll

From the "Prvt Ready" mode:

1. Press **◀▶** to select the person you want to private call.
2. Press and hold the PTT button, wait for the chirp, then speak into the microphone.
3. To listen, release the PTT button.

## Name Method

From the “Prvt Ready” mode:

1. Press  under “Name”.
2. Press the key with the first letter of the name associated with the Private ID.
3. Press  to find the desired name in the list.
4. Press and hold the PTT button, wait for the chirp, then speak into the microphone.
5. To listen, release the PTT button.

## Receiving a Private Call

When you receive an incoming Private Call, you hear a brief chirp-like tone. Your *i1000plus* automatically switches to Private mode, and the Private ID or the name of the caller displays.

Wait for the caller to finish speaking, then press and hold the PTT button. Begin speaking after you hear the chirp.

## Call Alert™



Call Alert lets you privately page an individual by sending an audible alert. You’ll want to send a Call Alert when you do not need an immediate response. The alert plays intermittently until the individual clears it. Call Alert allows you to contact another Nextel Direct Connect subscriber at no cost and avoid airtime charges.

## Sending a Call Alert

Once you have programmed Private IDs into your list, you can send a Call Alert with the cover closed or open.

### Cover Closed



From the “Prvt Ready” mode:

1. Press  under “List”. Use the Volume Control buttons to scroll to the desired name or ID.
2. Press  under “Alert”, then press the PTT button.



## Cover Open

From the "Prvt Ready" mode:

1. Press  under "Alert".
2. Press  to scroll to the desired name. *You may also select the name by pressing  and using the Name Method.*
3. Press the PTT button to send the Call Alert.



## Receiving a Call Alert

When you receive a Call Alert, you hear a brief chirp-like tone, and see a message on your display with the name or number of the caller.

- To answer the Call Alert, press the PTT button, wait for the chirp, then speak; release to listen.
- Or, to clear the Call Alert, press  under "Clear", or press any key other than the PTT button.

---

**NOTE:** Until the Call Alert is cleared or returned, you will not receive any additional Phone, Private, Group, or Net calls (future availability).



---

## Call Alert Queuing

Call Alert Queuing is a feature that allows you to save up to eight Call Alerts in a list.

### Receiving a Call Alert Queuing

When you receive a Call Alert Queuing, you can either clear the Call Alert or save it to the list for later recall.



- To clear a Call Alert, press  under "Clear".
- Or, to place the Call Alert into the queue, press  under "Queue". Pressing  also queues the Call Alert.



If you receive multiple Call Alerts, the last received Call Alert displays and the remaining Call Alerts are stacked at the beginning of the queue.

## Responding to a Call Alert within the Queue





You can respond to the Call Alerts in any order. To select a Call Alert for response:

1. Press  under “Queue”.
2. Press  to scroll to the desired Call Alert.
3. Press the PTT button to respond to the Call Alert. After you respond to the Alert, it is removed from the queue.

## Group Calls

Much simpler than setting up a conference call, a Group call allows you to instantly communicate with members of a selected group—a pre-defined set of individuals who share a common communication need. This group is called a Talkgroup.

Talkgroups appear on your display as numbers or programmed names, such as, SALES TEAM or Talkgrp5. You’ll want to make a Group call if you want to talk to more than one person at a time.

Either your sales representative or Nextel Customer Care (1-800-639-6111) can help you set up your Talkgroups. After they give you your Talkgroup number, you can name the talkgroup by entering , , , . Then, follow the instructions in “Adding and Storing a Talkgroup” on page 61.

## Making a Group Call

### Cover Closed

To contact the last group that you called:

1. From the “Group Ready” mode, press and hold the Push-to-Talk (PTT) button.
2. Wait for the chirp, then speak into the microphone.
3. To listen, release the PTT button.

To select a talkgroup from your talkgroup list:

1. From the “Group Ready” mode, press  under “List”.
2. Use the Volume Control buttons to scroll to the desired talkgroup name.
3. Press and hold the PTT button to talk now, or press “Ok”.

## Cover Open

To contact the last group that you called:

1. From the "Group Ready" mode, your most recently used talkgroup displays, for example, "Talkgrp 10".
2. To place a call to this talkgroup, press and hold the Push-to-Talk (PTT) button.
3. Wait for the chirp, then speak into the microphone.
4. To listen, release the PTT button.



To select a talkgroup from your talkgroup list:

1. Press  to scroll to the desired talkgroup name.
2. Press and hold the PTT button to talk now, or press "Ok" to select the talkgroup.

## Receiving a Group Call

When you receive an incoming Group call, you will hear a brief chirp-like tone. Your *i1000plus* automatically switches to Group mode, and the talkgroup name displays.

Your phone must be idle, that is, not busy in an active call or on the browser in Net Mode (future availability).

To join a Group call:

1. Wait for the caller to finish speaking.
2. Press and hold the PTT button. Begin speaking after you hear the chirp.
3. To listen, release the PTT button.

*You can receive group calls only in the talkgroups that you have predefined.*

Any communication activity within the talkgroup that you select automatically switches your phone into Group mode.

## Adding and Storing a Talkgroup

Your *i1000plus* can store up to 30 predefined talkgroups.

To add and store a talkgroup name to your *i1000plus*:

1. Press **\*←**, **#**, **2 ABC**, **3 DEF**.
2. Press **•** under "Ok".
3. At "Add New Entry?", press **•** under "Ok".
4. At "Enter ID", enter the desired talkgroup number.
5. Press **•** under "Store".
6. At "Enter Name", enter the desired talkgroup name.
7. Press the option key under "Store".

## Group-Silent Programming

If you set the Group-Silent programming menu to silence incoming alerts and voices, the "Group Ready" screen displays as "Group-Silent".

To reset it:

1. Press **\*←**, **#**, **3 DEF**, **8 TUV**.
2. Select "Off", then "Exit".

## USING YOUR PHONE AS A MODEM

With Nextel Online Dial-up Services, you can use your *i1000plus* as a modem for your IBM™ PC-compatible laptop computer (using Microsoft® Windows). This is particularly useful when there is no wired phone line (wall jack) available.

With this service, simply connect the data cable to your computer and to the *i1000plus* phone. This will allow you to send or receive time-critical information such as e-mail, a field service report, or files.

**Note:** To take advantage of this feature, you must subscribe to Nextel Online Dial-up Services. For more information, contact your Nextel Authorized Representative.

### TTY USERS

You can use your phone and computer in TTY mode. Your computer screen and keyboard replace the standard TTY device. For more information, please see the *Nextel Online Dial-up Services User's Guide* that is included with data cable accessories. Contact your Nextel Authorized Representative for more information.

## PROGRAMMING MENUS

You can customize the settings on your phone using the programming menus. Many of them have been discussed throughout this guide.

You may access this menu from the Phone, Private, or Group modes.

1. Press **MENU** until you see “Prgm” on the display.
2. Press **•** under “Prgm”.
3. Press **•** under “Ok”.
4. Press **◀▶** to scroll to the desired programming menu option or enter the option keypad number.

---

**SHORTCUT:** Press **\*◀**, press **#▶**, then press the keypad number. See Table 7.

---

**Table 7: Programming Menu Options**

Press-Keypad Number	Menu Option	To
1	Own Ph #	Automatically store the telephone number of your Nextel phone after you receive the first incoming call. Or, you can enter the number. Also, view your number. See “Programming Your Own Phone Number” on page 12.
2	Own Pvt ID	Display the private number of your phone. You must first store this number. See “Programming Your Own Phone Number” on page 12 and “Call Alert™” on page 57.
3	Mail Display:On/Off	Turn on and off the New Mail message that is displayed with incoming Voice, Message, or Net Mail (future availability).

Table 7: Programming Menu Options (Continued)

Press-Keypad Number	Menu Option	To
4	Manual Lock:On/Off	Lock your phone to prevent unauthorized use. You must enter a password to unlock it. Even with the manual lock on, you can reach emergency help by pressing and holding the  key.
5	Auto Lock:On/Off	Automatically lock your phone each time it is powered off to prevent unauthorized use.
6	Auto Answer:On/Off	Turn on or off automatic answering of incoming phone calls after 1-4 rings.
9	Vibrate Alert:On/Off	Provide non-audible notification of incoming phone and Nextel Online Data calls and messages. See "VibraCall" on page 19.
10	Last Call Timer	Display the duration of the most recent phone call.
11	Display Timer:On/Off	Turn on or off automatic display of the Last Call Timer at the end of each phone call.
12	Reset Timer	Display cumulative airtime of all phone calls since the last time the timer was reset.
13	Total Timer	Display cumulative airtime of all phone calls.
14	1 Minute Beep:On/Off	Automatically signal each minute of elapsed phone airtime with an audible beep.

Table 7: Programming Menu Options (Continued)

Press-Keypad Number	Menu Option	To
20	Phone/Prvt List	Add phone and private numbers in one procedure. See “Combined Phone Number and Private ID List Programming” on page 21.
21	Phone List Edit	Edit or erase up to 100 frequently called phone numbers and associated names. See “Editing and Erasing Phone List Entries” on page 23.
22	Prvt ID List Edit	Edit or erase up to 100 Private numbers and associated names. See “Editing and Erasing Private ID List Entries” on page 23.
23	Talkgrp List Program	Add, edit, or erase numbers and associated names for up to 10 pre-programmed talkgroups. See “Adding and Storing a Talkgroup” on page 61.
24	Area List Program	Add, edit, or erase numbers and associated names for up to 50 targeted areas.
30	Ringer Volume	Set the ringer volume using the volume control keys, or lower the volume to silence the ringer.
31	Set Ring Style	Select a distinct ring style for incoming phone calls.

Table 7: Programming Menu Options (Continued)

Press-Keypad Number	Menu Option	To
32	Mail Volume	Set the volume of incoming pages, Voice Mail, and Net alert tones (future availability) using the volume control keys. Or lower the volume to silence the mail alert tones.
33	Earpiece Volume	Set the default earpiece volume using the volume control keys.
34	Keypad Volume	Set the volume of the keypad tones using the volume control keys, or to silence the keypad tones.
35	Speaker Volume	Temporarily adjust the Private/Group speaker volume for noisy environments.
36	Spkr Vol Set Tone	Turn the speaker volume set tones on or off.
38	Silent Group	Silence all incoming Group Call alerts and voice activity. When set, your screen displays the message, "Group-Silent". See "Group-Silent Programming" on page 61.
40	Change Passcode	Change your secret four-digit password from the initial setting 0000.

Table 7: Programming Menu Options (Continued)

Press-Keypad Number	Menu Option	To
60	Set Baud Rate	Set the modem baud rate between the phone and the PC. See <i>Nextel Online Dial-up Services User's Guide</i> .
61	Data Ring Volume	Set the default data ringer volume using the volume control buttons. See <i>Nextel Online Dial-up Services User's Guide</i> .
62	Program Data #	View your circuit data number. See <i>Nextel Online Dial-up Services User's Guide</i> .
63	IP Address	View the Internet Protocol (IP) Address-1 for your browser, as programmed in your phone. If your phone is cabled to a computer, view IP Address-2, the stored IP address of your computer. Use the scroll keys to view either one. (Future availability)
64	Reset kBytes Tx/Rx	View the number of Kilobytes sent and received for packet data. (Future availability)
65	Lines per Screen	For message mail, select 4 lines, 12 characters or 6 lines, 16 characters.

Table 7: Programming Menu Options (Continued)

Press-Keypad Number	Menu Option	To
70	Language	Select one of four languages for your display text. <i>The default is English.</i> See "Changing the Display Language" on page 11.
71	Time/Date	Select the standard or military time and MM/DD or DD/MM date format.

---

**NOTE:** Do not try to program menus 41 through 51 as you could permanently damage your phone. They are for Nextel Customer Care use only and should never be programmed by customers.

---

Table 8: Other Programming Menu Options

Option Number	Menu Option	Function
41	Feature Reset	Returns all feature settings to their original defaults.
42	Master Clear	Performs Feature Reset and erases all stored lists.
43	Master Reset	Resets the phone's identification number.
44	Change Service Key	Changes or resets the fraud prevention service key.
50	NAM	Selects alternate Numeric Assignment Module (NAM).
51	Net ID	Edits the pre-programmed Network number list and select roaming options.

# ACCESSORIES

## Batteries

- NOTE:**
- For best results, charge the batteries within the temperature range of 10°C to 40°C (50°F to 104°F).
  - Prolonged charging is not recommended. For battery charging guidelines, see Table 9.

### *Charging Lithium Ion Batteries*

Table 9 provides the approximate time to fully charge a battery using a Motorola iDEN Approved Lithium Ion battery charger.

**Table 9: Battery Charging Times**

MOTOROLA BATTERIES		
Kit Number	Description/Chemistry	Charging Time*
NTN1645	Slim Lithium Ion	2.5 Hours
NTN1644	Standard Lithium Ion	3 Hours

\* Charging times are based on a fully discharged battery.

For optimal battery life, use a Motorola iDEN Approved Lithium Ion battery charger with your Motorola iDEN Lithium Ion battery. Other chargers may not fully charge your Lithium Ion battery or may yield a reduced number of cycles.

### *Battery Operating Instructions*

- Extreme temperatures will degrade battery performance. Do not store your battery where temperatures exceed 60°C (140°F) or fall below -20°C (4°F).
- This Lithium Ion battery has a self discharge rate and without use, will lose about 1% of its charge per day.
- The battery capacity will be degraded if stored for long periods while fully charged. If long term storage is required, store at half capacity.
- The Motorola iDEN Approved Lithium Ion chargers will provide optimum performance. Other chargers may not fully charge your iDEN Lithium Ion battery or may yield reduced number of charge cycles.
- If the battery appears inoperative, the internal protection circuitry may have been activated. Remove the battery from the phone and put it into the charger for several minutes to reset the circuitry.
- When batteries are not in use, always store them in the plastic safety tray.

## Travel Charger

Using the NPN6197 Travel Charger, you can charge a battery from an AC outlet. On one end of the Travel Charger, an accessory connector attaches to the bottom of the phone unit. At the other (AC outlet) end of the device, there is a compact housing that contains the plug-in power supply. A lightweight cable connects the two ends (accessory connector and supply). A power light (green LED) on the accessory power supply indicates that the Travel Charger is plugged in.

### *Using the Travel Charger*

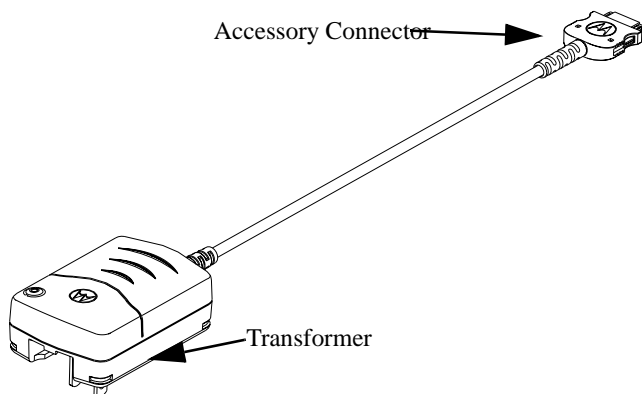

**Figure 1. Using the Travel Charger**

1. While holding the *i1000plus* with its front toward you, insert the accessory connector (with the Motorola logo facing you) into the slot on the bottom of the *i1000plus* until you hear a click.
2. Flip open the prongs, and plug the Travel Charger transformer into an AC wall outlet. The power light (green LED) on the accessory power supply will come on.

### *Travel Charger Operating Specifications*

Input voltage range: 90-264 VAC @ 50/60 Hz.

Operating temperature range: 0°C to +50°C

## Cigarette Lighter Adapter

The NTN1628 Cigarette Lighter Adapter provides power to the phone and charges the phone's Lithium Ion battery.

The power light (green LED) will light when the adapter is receiving power.

### *Using the Cigarette Lighter Adapter*

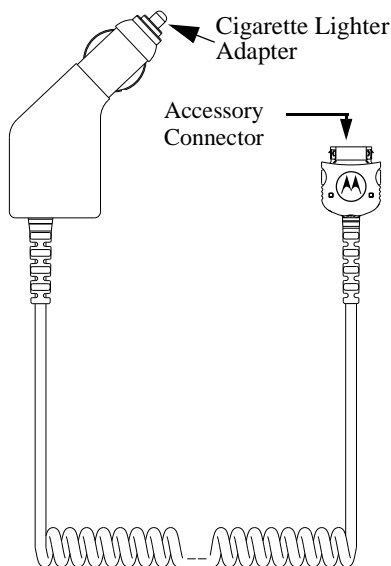

**Figure 2. Using the Cigarette Lighter Adapter**

1. Attach the Cigarette Lighter Adapter's accessory connector to the bottom of the *i1000plus*. While holding the *i1000plus* with its front toward you, insert the accessory connector (with the Motorola logo facing you) into the slot on the bottom of the *i1000plus* until you hear a click.
2. Remove the vehicle's cigarette lighter plug from the cigarette lighter receptacle.
3. Plug the cigarette lighter adapter into the cigarette lighter receptacle. The power light (green LED) will come on.
4. The *i1000plus* may be turned off, turned on, or in use.

### *Removing the Cigarette Lighter Adapter*

1. Unplug the adapter's cigarette lighter adapter from the vehicle's cigarette lighter receptacle.
2. Press the latches on the accessory connector.
3. Pull the accessory connector from the bottom of the *i1000plus*.

## **Cigarette Lighter Adapter Operating Specifications**

Operating voltage range: 10.8 - 33.0 Vdc.

Operating temperature range: -30°C to +60°C

## **Desktop Dual-Pocket Charger**

The NTN1627 Desktop Dual-Pocket Charger charges Motorola authorized batteries, as listed on page 69, for the *i1000plus*. To charge a battery, see Figure 3.

### **Charging a Battery**

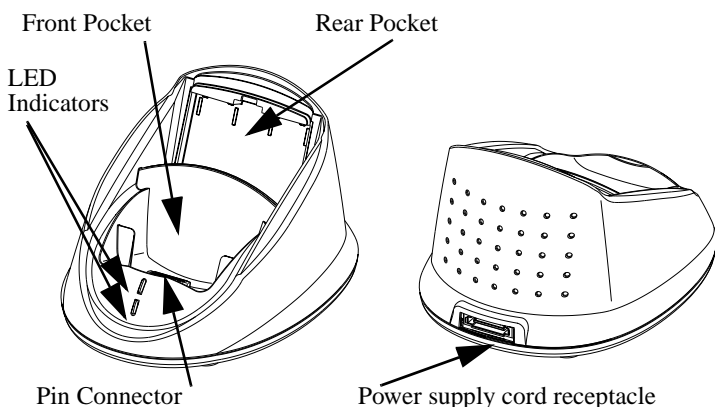

**Figure 3. Desktop Dual-Pocket Charger**

1. Plug the flat end of the power-supply cord, with the Ⓜ logo facing down, into the receptacle labeled "Charging" on the back of the charger.
2. Plug the transformer end of the power-supply cord into any standard AC wall outlet.
3. Insert an *i1000plus* with an attached battery, into the charger's front pocket. This is done by inserting the bottom of the *i1000plus* into the pin connector in the bottom of the charger's front pocket.
4. If the *i1000plus* is properly seated in the front pocket, the charger's front pocket LED indicator will light green to indicate that the battery is being charged. If a battery is in the rear pocket and the *i1000plus* with a battery is inserted into the front pocket, the battery in the front pocket will charge to full capacity before the battery in the rear pocket is charged. The LED for the rear pocket will flash yellow, indicating that its battery is waiting to be charged.
5. The charger has the capability of displaying the battery's charge status. The indicator will show the following: solid red=1-30%; solid yellow=31-60%; flashing green=61-90%; solid green=91-100%.

## Audio Adapter

The Audio Adapter connects an earpiece microphone to your *i1000plus* for privacy and hands-free operation.

The Audio Adapter fits onto the bottom of the *i1000plus* and provides a standard 2.5mm jack connection for an earpiece microphone or headset. (The Audio Adapter will be packaged with an audio accessory, such as an earpiece microphone or a headset.)

### Using the Audio Adapter

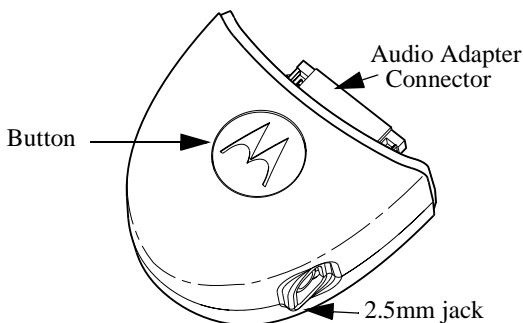

**Figure 4. Using the Audio Adapter**

1. Hold the phone and the Audio Adapter facing you so that you see the Motorola logo on the adapter.
2. Insert the Audio Adapter's connector into the *i1000plus* receptacle. You will hear the connector snap into place.

### Attaching/Detaching the Earpiece Microphone

1. Insert the 2.5mm plug of the earpiece microphone cord into the jack of the Audio Adapter.
2. Pull on the plug, not the cord, to remove the earpiece microphone.

### Removing the Audio Adapter

1. Press the button on the front of the Audio Adapter. The button displays the Motorola logo.
2. Pull the Audio Adapter from the *i1000plus*.

## **OTHER USEFUL INFORMATION**

### **Frequently Asked Questions**

#### **Q. Which services or calling features follow me when I travel?**

**A.** All digital cellular calling services, including Voice Mail, Paging and related features follow you no matter where you use your phone on the Nextel National Network. Nextel Direct Connect can be used only in your local market.

#### **Q. What number is dialed to reach me when I'm traveling on the Nextel National Network?**

**A.** Every Nextel subscriber gets a regular 10-digit Personal Telephone Number — a 3-digit area code, plus a 7-digit local number. This number is used just like any phone number. And it doesn't matter where you're traveling on the Nextel National Network...you'll get the call. However, if you are traveling long distance and someone calls you from your home market using only your 7-digit number, you will be charged long distance for the call.

#### **Q. How are calls on the Nextel National Network priced?**

**A.** Local calls are priced according to your home market rates, no matter where you are on the Nextel National Network. For long distance calls, you are charged a flat rate per minute, no matter where you call in the U.S. There are no roaming charges associated with any digital calls made while traveling, and there are no incremental access fees to pay for use of the network.

#### **Q. If I live in Chicago, travel to Denver and make a local call there, how will that call be priced?**

**A.** Local is always local with Nextel! You will be charged local rates, because a local call placed in Denver is a local call, regardless of where your home market is located.

#### **Q. What do I do if I have additional questions or my phone breaks?**

**A.** Call Nextel Customer Care at 1-800-639-6111 or dial 611 on your Nextel phone. However, if you are having problems with your *i1000plus*, whenever possible, call Customer Care from another phone as you may be asked to go through steps to correct the problem on your phone.

## **Nextel Customer Care**

Relax! Nextel Customer Care is here to help. There are lots of features packed into your Nextel service...and into your *i1000plus* phone. But don't worry. If, after reading this guide, you still have questions about coverage, billing, Nextel Direct Connect or any other service or feature, call us.

We'll be happy to give you help, explanations and anything else you need to enjoy your Nextel service as soon as possible!

Before you call Nextel Customer Care for service or to resolve an issue, be sure to have your IMEI number and your model number ready. These numbers are located behind the battery on the back of your Nextel phone. You'll want to record these numbers, and keep them handy, so that you can replace the battery prior to making your call.

## Understanding Status Messages

You may receive status messages under certain conditions. Before contacting your carrier, note the message, numeric code, and the conditions under which it appeared. The following table lists and describes the status messages.

Status Messages	Message Description
Number Not in Service	The number that you entered is not valid.
User Not Available	The phone that you called is either busy, out-of-range, or turned off. Please try again later.
User Not Authorized	The party that you called has not purchased this service.
Please Try Later	This service is temporarily not available. Please try again later.
User Busy in Private	The phone that you called is busy in a Private call.
User Busy in Data	The phone that you called is busy in a dial-up call.
Service Restricted	This service was restricted by your service provider or it was not purchased.
Service Not Available	This feature is not available on the current network.
System Busy Try Later	The system is experiencing heavy traffic. Please try again later.
Service Conflict	This service cannot be enabled because an incompatible service has already been turned on.
Please Try Again	An error occurred. Note the error code and try again.
Self Check Error	A fault was detected with your Nextel phone. If this error recurs, note the error code and contact Customer Care.
Self Check Fail	An operational fault was detected with your phone. Note the numeric code, turn your Nextel phone off, and contact Customer Care.

## **TERMS AND CONDITIONS OF SERVICE**

**TERMS AND CONDITIONS OF SERVICE:** Before calling the Nextel Customer Service Activation Number contained in these materials, you ("Customer") must read and agree to the following terms and conditions of Nextel wireless telephone service ("Service"). By calling to activate service, Customer applies and subscribes for Services provided by Nextel (the "Company") and confirms that Customer has read, understands, agrees to and accepts the terms and conditions stated herein. Customer understands that Company will rely upon the information provided by Customer including credit information, in making a decision to provide Services. Customer understands that Company may request and verify Customer's bank references and perform a credit history check utilizing standard commercial credit reference services in connection with Company's review of the Customer's credit worthiness. Customer understands that a security deposit or air time usage limit may be required.

1. **USE OF SERVICE** — Customer must comply with all FCC rules and regulations. Customer will not use the Service for any unlawful purpose. Customer will not use the Service in aircraft.
2. **CREDIT APPLICATION** — This Agreement shall be contingent upon Company's approval of Customer's credit. Company may require Customer to update credit information from time to time. Customer warrants and represents that all credit information furnished is complete, accurate and true. If Company subsequently determines that any statements regarding Customer's credit are false, incomplete or inaccurate, Company may declare Customer to be in default and may exercise any remedies it has under these Terms and Conditions of Service and at law or in equity.
3. **CUSTOMER RADIO EQUIPMENT** — Company is not responsible for the installation, operation, quality of transmission or maintenance of the equipment. Company reserves the right to change or remove assigned codes and/or telephone numbers when such change is reasonably necessary in the conduct of its business. Customer does not have any proprietary interest in such codes or telephone numbers. Federal and state laws make it illegal for third parties to listen in on service, however complete privacy cannot be guaranteed.
4. **SECURITY DEPOSITS** — Company has the right, in its sole discretion, to require Customer to make a deposit to guarantee payment of Service charges. Customer grants Company a security interest in such deposits, to secure the payment of all sums due thereunder as well as the performance of all other obligations Customer may have to the Company whether now existing or hereafter arising. Upon termination of Service, Company may apply the deposit against any outstanding Service charges of Customer or any other amount owed to Company. Company reserves the right to interrupt services if service appears to have excessive charges or any unusual calling patterns are observed on Customer's account. Such interruption may be done to protect Customer or Company as the Company determines in its sole discretion.
5. **RATES, CHARGES AND PAYMENTS** — Company shall issue invoices for Service on a monthly basis which are due and payable upon receipt. Monthly Access Charges shall be invoiced in advance. Airtime and long-distance charges shall be invoiced in arrears. Customer is responsible to pay Company on a timely basis, for charges for Service payments as set forth on the Company's then-current rate plans, and any modifications thereto. Customer acknowledges that chargeable time for telephone calls originated by a unit begins when a connection is established with Company facilities. Customer accepts responsibility for Airtime charges from invoicing telephone calls to its mobile unit from the time that Customer responds to the call. If Customer disputes any Service charges, Customer must pay entire amount set forth in the invoice by the due date and submit a written explanation within forty-five (45) days from the date on the invoice. If Company

determines that an error was made on Customer's invoice, Company shall credit Customer's account in the amount of the error. If Customer does not pay the amount in dispute, Company may exercise any remedies it may have for non-payment of Service charges. Company reserves the right to modify any and all elements of the Service charges at any time. Payments which are not received within thirty (30) days from the day of the invoice shall be subject to late payment charges. If Customer does not make payments, such failure shall be a default and Company shall be entitled to exercise any remedies it may have under these Terms and Conditions of Service or at law or in equity.

6. **NONPAYMENT/BREACH** — A late payment charge of 1.5% (or the maximum interest rate permitted by law) per month, may be applied to Customer's account if monthly invoices are not paid by the due date. The later payment charge is applied to the total unpaid balance due and outstanding. The late payment charge is for costs related to the non-timely payment and shall be deemed an interest payment. A charge of \$25.00 will be made by Company for any check or negotiable instrument tendered by Customer and returned unpaid by a financial institution for any reason. Company may demand payment by money order, cashier's check or similarly secure form of payment, at Company's discretion. If Company obtains the service of a collection or repossession agency or an attorney to assist the Company in remedying Customer's breach of any payment obligations, Customer shall be liable for this expense. Customer understands that in the event of nonpayment of charges or any other breach of these Terms and Conditions of Service in addition to any other remedies the Company may have, Company may temporarily or permanently terminate Service to Customer. If Company disconnects the Service, Customer shall be liable to pay a re-connect charge of \$25.00 per unit, in addition to the outstanding Service charges before the Company will reactivate Service. Company reserves the right to modify the terms of service as a precondition to reactivating service.

7. **TAXES** — Customer is responsible for all federal, state and local taxes for fees which are computed in accordance with the appropriate tax laws for Services.

8. **LIMITATION AND CONDITION OF LIABILITY/INDEMNITY** — The Company's sole liability for Service disruption, whether caused by the negligence of the Company or otherwise, is limited to a credit allowance not exceeding an amount equal to the proportionate charge to the Customer for the period of Service disruption. In no event is the company or lessor liable for actual consequential or special damages caused by its negligence or otherwise nor for economic loss, personal injuries or property damages sustained by customer or any third parties. Customer agrees to indemnify, defend and hold Company harmless from any Customer violations of FCC rules and regulations or Customer violation of any statutes, ordinances or laws of any local, state or federal public authority.

9. **NOTICE REGARDING USE OF SERVICE FOR 911 OR OTHER EMERGENCY CALLS** — The Service provider hereunder does not interact with 911 and other emergency services in the same manner as land line telephone service. Depending on the circumstances of a particular call, the Service provided hereunder may not be able to identify your location to emergency services and may not always be connected to the appropriate emergency services provider. Customer agrees to hold company harmless against any and all claims, demands, actions or causes of action (including all actions by third parties) arising out of the use or attempted use of the company's service to access 911 or other emergency services.

10. **NO WARRANTY (SERVICE)** — Company makes no warranties, express or implied, including without limitation, any implied warranty of merchantability or fitness for a particular purpose to customer in connection with its use of the service. In no event shall company be liable for incidental or consequential damages to the full extent the same may be disclaimed by law. Customer acknowledges that service interruptions will occur from

time to time and agrees to hold company harmless for all such interruptions.

11. NO WARRANTY (EQUIPMENT) — Company makes no warranties or representations of any kind, statutory, expressed or implied, to customer or any other purchaser of equipment activated on the service. Without limiting the foregoing, company specifically makes no express or implied warranties of merchantability or fitness for a particular purpose. Customer hereby waives all other warranties, guarantees, conditions or liabilities, express or implied, arising by law or otherwise. In no event shall company be liable for consequential, special or incidental damages, whether or not occasioned by company negligence and including, without limitation, liability for any loss or damage resulting from the interruption or failure in the operation of any equipment activated on the service. There are no warranties which extend beyond the description contained herein. Customer assumes the entire risk as to the quality and performance of the equipment. If the equipment proves defective, the costs of all necessary servicing and repair will be borne by the customer.

12. NEXTEL BUSINESS NETWORKS -- There is no group call available on the Nextel Business Networks. There is no pooling of Nextel Direct Connect minutes between companies on the Nextel business networks. It is possible that participants on the Nextel Business Network could determine the private identification numbers of customer's units and be able to private call those units. It is also possible that users of customer units could determine the private identification numbers of other Nextel Business Network participants and private call them.

©1999 Nextel Communications, Inc. All rights reserved. Nextel, the Nextel logo, Nextel Direct Connect, NexNote, and Nextel Business Networks are trademarks and/or service marks of Nextel Communications, Inc.

™, Motorola, *i1000plus*, *VibraCall*, and *Call Alert*, are trademarks; and *iDEN* and *Turbo Dial* are registered trademarks of Motorola, Inc.

®*Reg. U.S. Pat. & Tm. Off.*

# SAFETY AND GENERAL INFORMATION

---

**IMPORTANT INFORMATION ON SAFE AND EFFICIENT OPERATION.  
READ THIS INFORMATION BEFORE USING YOUR INTEGRATED MULTI-SERVICE PORTABLE RADIO.**

---

## **For the Safe and Efficient Operation of Your Radio, Observe these Guidelines:**

Your radio product contains a transmitter and a receiver. When it is *ON*, it receives and transmits radio frequency (RF) energy. The radio operates in the frequency range of 806 MHz to 870 MHz and employs digital modulation techniques. When you use your radio, the system handling your call controls the power level at which your radio transmits. The power level typically may vary over a range from .0024 Watts to 0.6 Watts.

## **Exposure To Radio Frequency Energy**

Your Motorola Radio Product is designed to comply with the following national and international standards and guidelines regarding exposure of human beings to radio frequency electromagnetic energy:

- United States Federal Communications Commission, Code of Federal Regulations; 42 CFR part 2 sub-part j
- American National Standards Institute (ANSI) IEEE. C95. 1-1992
- National Council on Radiation Protection and Measurements (NCRP). Report 86
- International Commission on Non-Ionizing Radiation Protection (ICNIRP) 1998
- National Radiological Protection Board of the United Kingdom, GS 11, 1988
- Verband Deutscher Elektrotechniker (VDE) DIN-0848
- Department of Health and Welfare Canada. Safety Code 6

To assure optimal radio performance and make sure human exposure to radio frequency electromagnetic energy is within the guidelines set forth in the above standards, always adhere to the following procedures:

When placing or receiving a phone call, or using the group or private call functions with the Group/Private Speaker OFF (muted speaker icon visible in the display), hold the radio as you would a telephone. Speak directly into the mouthpiece and position the antenna up and over your shoulder.

When using the radio as a traditional two-way radio while making group or private calls with the Group/Private Speaker ON (no speaker icon visible in the display), hold the radio in a vertical position with the microphone one to two inches away from the lips.

For body-worn operation, the antenna should be kept at least one inch from the body when transmitting.

DO NOT hold the antenna when the radio is "IN USE". Holding the antenna affects call quality and may cause the radio to operate at a higher power level than needed.



## **Interference to Medical and Personal Electronic Devices**

Most electronic equipment is shielded from RF energy. However, certain equipment may not be shielded against the RF signals from your wireless phone.

### **Pacemakers**

The Health Industry Manufacturers Association recommends that a minimum separation of six inches (6") be maintained between a handheld wireless phone and a pacemaker to avoid potential interference with the pacemaker. These recommendations are consistent with the independent research by and recommendations of Wireless Technology Research.

Persons with pacemakers should:

- ALWAYS keep the phone more than six inches from their pacemaker when the phone is turned ON.
- not carry the phone in a breast pocket.
- use the ear opposite the pacemaker to minimize the potential for interference.
- turn the phone OFF immediately if you have any reason to suspect that interference is taking place.

### **Hearing Aids**

Some digital wireless phones may interfere with some hearing aids. In the event of such interference, you may want to consult your hearing aid manufacturer to discuss alternatives.

### **Other Medical Devices**

If you use any other personal medical device, consult the manufacturer of your device to determine if it is adequately shielded from external RF energy. Your physician may be able to assist you in obtaining this information.

Turn your phone OFF in health care facilities when any regulations posted in these areas instruct you to do so. Hospitals or health care facilities may be using equipment that could be sensitive to external RF energy.

## **Interference to Other Electronic Devices**

RF energy may affect improperly installed or inadequately shielded electronic operating and entertainment systems in motor vehicles. Check with the manufacturer or representative to determine if these systems are adequately shielded from external RF energy. Also check with the manufacturer of any equipment that has been added to the vehicle.

Turn your radio off before boarding any aircraft to prevent possible interference to aircraft systems. Regulations of the United States Federal Aviation Administration prohibit use when the plane is in the air and require you have permission from a crew member to use your radio while the plane is on the ground.

## **Safety and General**

### **Use While Driving**

Check the laws and regulations on the use of telephones in the area where you drive. Always obey them.

When using the phone while driving, please:

- Give full attention to driving and to the road
- Use hands-free operation, if available
- Pull off the road and park before making or answering a call if driving conditions so require.



## OPERATIONAL WARNINGS

### **WARNING** POTENTIALLY EXPLOSIVE ATMOSPHERES

Turn off your two-way radio when you are in any area with a potentially explosive atmosphere, unless it is a radio type especially qualified for use in such areas (for example, Factory Mutual Approved). Sparks in a potentially explosive atmosphere can cause an explosion of fire resulting in bodily injury or even death.

**Note:** *The areas with potentially explosive atmospheres referred to above include fueling areas such as: below decks on boats; fuel or chemical transfer or storage facilities; areas where the air contains chemicals or particles such as grain, dust or metal powders; and any other area where you would normally be advised to turn off your vehicle engine. Areas with potentially explosive atmospheres are often, but not always, posted.*

### **Batteries**

Do not replace or charge batteries in a potentially explosive atmosphere. Contact sparking may occur while installing or removing batteries and cause an explosion.

### **BLASTING CAPS AND AREAS**

To avoid possible interference with blasting operations, turn off your radio when you are near electrical blasting caps, in a blasting area, or in areas posted: "Turn off two-way radio". Obey all signs and instructions.

### **FOR VEHICLES EQUIPPED WITH AN AIR BAG**

Do NOT place objects, including both installed and portable wireless equipment, in the area over the air bag or in the air bag deployment area. An air bag inflates with great force. If in-vehicle wireless equipment is improperly installed and the air bag inflates, serious injury could result.



**Caution**

## **OPERATIONAL CAUTIONS**

### **Damaged Antennas**

Do not use any portable two-way radio that has a damaged antenna. If a damaged antenna comes into contact with your skin, a minor burn can result.

### **Batteries**

All batteries can cause property damage and/or bodily injury such as burns if a conductive material such as jewelry, keys, or beaded chains touch exposed terminals. The conductive material may complete an electrical circuit (short circuit) and become quite hot. Exercise care in handling any charged battery, particularly when placing it inside a pocket, purse, or other container with metal objects.

### **Cleaning Instructions**

Clean the external surfaces of the unit with a damp cloth, using a mild solution of dishwashing detergent and water. Some household cleaners may contain chemicals that could seriously damage the unit. Avoid the use of any petroleum-based solvent cleaners. Also, avoid applying liquids directly on the unit.

### **Antenna Considerations**

Use only the supplied or an approved antenna. Unauthorized antennas, modifications, or attachments could impair call quality, damage the radio, or result in violation of local agency regulations.

## Accessory Safety Information

### IMPORTANT:

#### SAVE THESE ACCESSORY SAFETY INSTRUCTIONS

- Before using the battery, read all the instructions and cautionary markings on (1) the battery, (2) the battery charger, and (3) the phone using the battery.
- For your protection, store the battery in its safety tray when you are not using it.
- Before using the Travel Charger, read all the instructions and cautionary markings on (1) the Travel Charger, (2) the battery, and (3) the phone using the battery.
- Before using the Cigarette Lighter Adapter (CLA), read all the instructions and cautionary markings on (1) the CLA, (2) the battery, and (3) the phone using the battery.
- Before using the Desktop Charger, read all the instructions and cautionary markings on (1) the battery charger, (2) the battery, and (3) the phone using battery.
- Do not expose the Travel Charger, Desktop Charger, or CLA to water.



### WARNING

To reduce the risk of injury, charge only the rechargeable batteries listed. Other types of batteries may burst, causing personal injury and damage.

- To reduce the risk of damage to the cord or plug, pull by the plug rather than the cord when you disconnect the Travel Charger or Desktop Charger from the AC receptacle or when you disconnect the CLA from the cigarette lighter.
- Do not operate the Travel Charger or CLA with a damaged cord or plug.
- Do not attempt to disassemble the Travel Charger or CLA.
- The Travel Charger or CLA may become warm during operation, but not hot. If the Travel Charger becomes hot to the touch, unplug it from the AC outlet immediately and discontinue its use. If the CLA becomes hot to the touch, unplug it from the cigarette lighter immediately and discontinue its use.
- Use of a non-recommended attachment to the Desktop Charger may result in a risk of fire, electric shock, or injury to persons.
- Make sure the Desktop Charger cord is located so that it will not be stepped on, tripped over, or subjected to damage or stress.
- An extension cord should not be used with the Desktop Charger unless absolutely necessary. Use of an improper extension cord could result in a risk of fire and electric shock. If an extension cord must be used, make sure that:
  - The pins on the plug of the extension cord are the same number, size, and shape as those on the plug of the charger.
  - The extension cord is properly wired and in good electrical condition.

- ❑ The cord size is 18AWG for lengths up to 100 feet and 16AWG for lengths up to 150 feet.
- Do not operate the Desktop Charger with a damaged cord or plug - replace them immediately.
- Do not operate the Desktop Charger if it has received a sharp blow, has been dropped, or has been damaged in any way; take it to a qualified service technician.
- Do not disassemble the Desktop Charger; take it to a qualified service technician when service or repair is required. Incorrect reassembly may result in a risk of electric shock or fire.
- Maximum ambient temperature around the power supply of the Desktop Charger must not exceed 40°C (104°F).
- The output power from the power supply must not exceed the rating given on the Desktop Charger.
- The disconnection from the line voltage is made by unplugging the power supply's transformer from the AC receptacle.
- To reduce risk of electric shock, unplug the Desktop Charger from the outlet before attempting any maintenance or cleaning.
- For optimum performance, turn off the *i1000plus* while charging it in the Desktop Charger.
- The Desktop Charger is for indoor use only.

## **OWNER'S INFORMATION**

**Mobile Equipment Identifier (IMEI)**

---

**Own Phone Number**

---

**Own Private ID**

---

**Date Purchased**

---

**Sales Representative Telephone Number**

---

**Customer Care Number**

**1-800-639-6111**

# Directories

## *Private Call Directory*

<b>Private ID</b>	<b>Name</b>
1	
2	
3	
4	
5	
6	
7	
8	
9	

## *Talkgroup Directory*

<b>Talkgroup ID</b>	<b>Name</b>
1	
2	
3	
4	
5	
6	
7	
8	
9	

