

**Nextel®**

**iDEN®**

*Digital Multi-Service Phone*

***i2000™* Phone User's Guide**



**NTN9110A**

---

## **i2000™ Phone Features Bookmark**

You can use this fold-out diagram as a bookmark, making it easy to refer to while you learn to use your *i2000* phone.

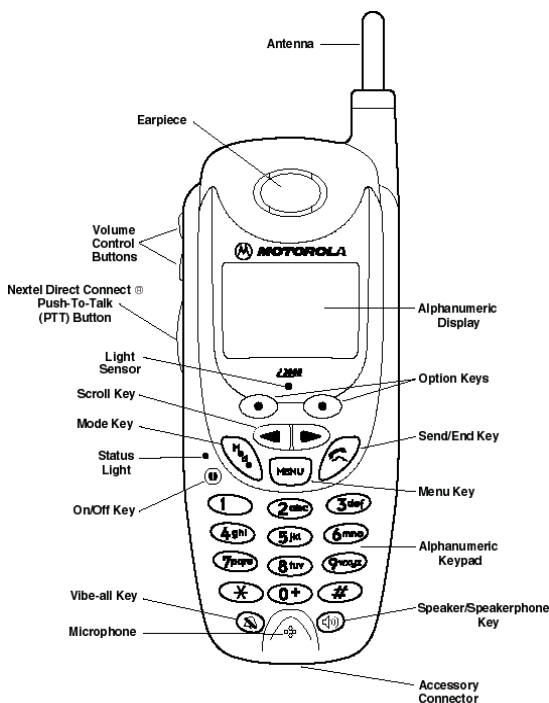

### **Learning to Use Your *i2000* Phone**

<b>1</b>	Tear off the Quick Reference Card located on the back cover, complete the information and keep it handy.
<b>2</b>	Read Safety and General Information.
<b>3</b>	Familiarize yourself with the Table of Contents.
<b>4</b>	Read Getting Started, which includes a Quick Guide to <i>i2000</i> Phone Functions.
<b>5</b>	View the <i>i2000</i> Phone Video included in the box.

**NOTE:** Remove the plastic film lens protector from the display.

---

# Table of Contents

i2000™ Phone Features Bookmark .....	2
Learning to Use Your i2000 Phone .....	2
<b>Table of Contents .....</b>	<b>i</b>
<b>Introduction .....</b>	<b>5</b>
Welcome to Nextel® .....	5
Questions? .....	7
Nextel Business Solutions.....	8
International Business Solutions .....	9
<b>Getting Started .....</b>	<b>11</b>
Getting Started.....	11
About This Section .....	11
Batteries.....	11
Attaching the Battery .....	12
Detaching the Battery .....	12
Charging the Battery .....	12
Turning Your i2000 Phone On/Off .....	13
Your Phone's SIM Card .....	14
..... SIM Card Personal Identification Number (PIN)	14
Entering the PIN.....	14
Keypad Lock .....	18
Activating Your i2000 Phone.....	20
Your Nextel Phone Status.....	21
Display Icons.....	22
Modes and Menus .....	23
Quick Guide to i2000 Phone Functions.....	24
Phone Mode .....	24
Private Mode* .....	25
Group Mode* .....	25
<b>Creating, Editing and Using Stored Lists .....</b>	<b>26</b>
Creating, Editing and Using Stored Lists .....	26
About This Section .....	26
Storing Names and Numbers.....	26
Pause Digit Entry .....	28
Editing Stored List Entries.....	29
Editing a Private ID or Associated Name .....	29
Erasing List Entries .....	30

<b>Phone Mode .....</b>	<b>31</b>
Phone Calls.....	31
About This Section .....	31
Programming Your Own Phone Number .....	31
Displaying Your Phone Number.....	32
Making Phone Calls .....	32
Making Calls From the Stored List.....	33
Emergency/Non-Emergency Dial.....	34
Placing International Calls With Plus Dialing .....	34
Plus Dialing .....	35
Using Hands-Free Speakerphone .....	35
Receiving/Ending a Phone Call .....	36
Missed Call Indicator .....	36
Retrieving Missed Calls.....	36
Last 10 Numbers Received/Sent Call List .....	37
Quickstore of Phone Numbers .....	37
Reviewing/Storing Received Calls .....	37
Reviewing/Storing Sent Calls.....	37
Nextel Voice Mail Service .....	38
About This Section .....	38
Voice Mail Features: Basic .....	38
Setting Up Your Voice Mailbox from Within the U.S. ....	39
New Message Indicators.....	39
About Voice Mail Menus .....	40
Logging Into Voice Mail.....	40
Listening Options .....	41
Listening Options (Quick Reference List).....	42
Listening to New Messages While Overseas.....	43
Saving/Deleting Messages.....	43
Choosing Order to Play Unheard Messages.....	44
Customizing Your Voice Mail Setup .....	44
Changing Your Password .....	44
Recording Your Name.....	45
Recording Your Active Greeting.....	45
Automatic Playback .....	46
Voice Mail Features: Advanced .....	47
Recording and Sending A Message.....	47
Special Delivery Options .....	48
.....	48
Greetings Schedule .....	49
Working With Group Lists .....	50
Message Forwarding.....	52
Time and Date Charts.....	53

---

Pager Notification.....	53
Additional Phone Services.....	55
About This Section .....	55
Call Waiting .....	55
Call Hold .....	56
Three-Way Calling .....	57
Call Forwarding .....	57
Transferring Calls to Voice Mail .....	58
Caller ID .....	58
Alternate Line Service (not available on GSM) .....	59
Text and Numeric Paging.....	62
About This Section .....	62
Text and Numeric Paging Features .....	62
Notification of New Pages .....	63
Accessing New Pages .....	63
.....	63
Auto Call Back .....	64
Sending a Page .....	64
Web Paging .....	64
E-Mail Paging.....	65
Numeric Paging .....	65
Operator Assisted Paging*.....	65
<b>Nextel Worldwide<sup>SM</sup> Service .....</b>	<b>66</b>
Nextel Worldwide Service .....	66
About This Section .....	66
Setting the Way Your Phone Searches for Networks .....	66
Manually Searching for a Network .....	67
Creating Your Phone's Network Priority List .....	68
<b>Private/Group Mode .....</b>	<b>73</b>
Nextel Direct Connect® .....	73
Displaying Your Private ID .....	74
Using the Private/Group Speaker .....	74
Placing Private Calls .....	74
Receiving Private Calls .....	75
Quickstore of Private IDs .....	75
Sending a Call Alert .....	76
Receiving/Responding to a Call Alert .....	76
Call Alert Queuing .....	77
Group Calls .....	77
.....	78
Group-Silent Programming .....	79

<b>Customizing the i2000 Phone .....</b>	<b>80</b>
Customizing the i2000.....	80
About This Section .....	80
Changing the Display Language .....	80
Setting the Time and Date Format.....	81
Setting the Ringer Volume .....	83
Setting VibraCall™.....	84
Programming Menus.....	86
Programming Menus Shortcut and Options .....	86
Ordering Information .....	90
<b>Accessories .....</b>	<b>91</b>
Accessories.....	91
About This Section .....	91
<b>Other Important Information .....</b>	<b>98</b>
About This Section .....	98
Nextel Customer Care.....	98
Understanding Status Messages .....	98
Nextel Terms and Conditions of Service.....	100
Safety and General Information .....	103
Warranty Information.....	110
Patent and Trademark Information .....	116
Index .....	CXV
<b>Index .....</b>	<b>CXV</b>

---

# Introduction

## Welcome to Nextel®

Thank you for choosing Nextel as your wireless communications provider. The *i2000* phone is one of the most sophisticated digital cellular instruments available today--offering you worldwide services so you can keep in touch with business and personal contacts.

When using your *i2000* phone, you'll enjoy crystal clear connections through two state-of-the-art services. Whether you are in the U.S. or travelling abroad, Nextel Worldwide<sup>SM</sup> Service provides cellular communication while in the U.S., Canada, Mexico, South America and Asia as well as Europe, Africa and the Middle East. For up-to-date information on Nextel Worldwide Service coverage see [www.nextel.com](http://www.nextel.com).

In addition to top-notch communication service, the *i2000* phone includes remarkable features such as a Subscriber Identity Module (SIM) card that holds all of your personal information, including a Personal Identification Number (PIN) for added security. It also holds your stored lists of names and phone numbers. Just as you protect your credit and bank cards with a PIN, you can safeguard your phone with a PIN to prohibit unauthorized use.

Lastly, before you get started, please refer to the “*i2000* Phone Features Bookmark” attached to the front cover of this guide. You can use this bookmark as a placeholder. It has a picture of the *i2000* phone with all of the components clearly labeled. Also, the back of this guide includes a topic Index to help you look up specific information in this guide.

This guide contains all the information you need to take full advantage of your Nextel Worldwide Service, including:

<b>Quick Guide to <i>i2000</i> Phone Functions</b> -- Enables experienced cellular phone and two-way radio users to get started right away!	Page 24
<b>Digital Cellular Calling</b> -- Nextel's Guaranteed All-Digital Network lets you enjoy a crystal-clear connection, with built-in call security, every time you place a phone call. Find out more about placing calls in this section.	Page 31
<b>Voice Mail</b> -- Takes messages 24-hours a day and includes other features such as <b>Schedule a Page</b> , which you can use to remind yourself about upcoming appointments and dates up to six months away. Read more about these features in this section.	Page 38

<b>Additional Phone Services*</b> -- Includes Call Forwarding, Call Waiting, Alternate Line Service and Three-Way Calling, which lets you conduct conference calls whether you're in the office or out on travel. Find out more in this section.	Page 56
<i>*These features may not be available on GSM networks.</i>	
<b>Text and Numeric Paging</b> -- Lets you receive important text and numeric pages right over the phone. Learn more about Paging in this section.	Page 63
<b>Nextel Worldwide<sup>SM</sup> Service</b> -- When you travel overseas, the phone will automatically search for iDEN and GSM network coverage to broaden your communication possibilities around the world. Learn more about this valuable service in this section.	Page 68
<b>Nextel Direct Connect<sup>®</sup></b> -- An innovative feature for communicating instantly with one or more co-workers at a fraction of the cost of cellular calls. Read more about Nextel Direct Connect in this section.	Page 75
<b>Programming</b> -- At Nextel, we know one size doesn't fit all—and this feature proves it! You can customize your i2000 phone and make it behave the way you want it to. Learn how in this section.	Page 82
<b>Other Nextel Advantages</b> -- In addition to all of the previously mentioned benefits, there's more... Nextel features also include the following: <ul style="list-style-type: none"><li>• The guaranteed all-digital Nextel National Network</li><li>• No Roaming Fees while traveling throughout the U.S.</li><li>• One-second call rounding after the first minute</li><li>• Flat-rate long distance pricing to anywhere in the continental U.S.</li><li>• No landline connection charges</li></ul>	

**NOTE: Are you an experienced digital phone and two-way radio user? Turn to the Getting Started section beginning on Page 11. This section might be all you need to get started.**

For more information about Nextel or to view this guide on our web site, visit us at [www.nextel.com](http://www.nextel.com).

## Questions?

To complement the *i2000* phone and Nextel Worldwide Service, Nextel has also launched International Roaming Customer Care support. For specific International roaming questions (such as coverage and rates) and Customer Care Service when traveling overseas call 1(201) 531-5202. This Customer Care number will be toll-free from your Nextel handset both domestically and internationally.

International and Domestic Coverage, Rates and other information is also available at [www.nextel.com](http://www.nextel.com).

For domestic customer care issues including billing issues, general service needs, or to order additional services, call Nextel Customer Care at 1-800-639-6111, or dial 611 from your *i2000* phone.

## **Nextel Business Solutions**

The i2000 phone, Nextel's Guaranteed All-Digital National Network and Nextel Worldwide Service join forces to provide the only office small enough to fit in your pocket. Below is a list of innovative solutions that will help you get the most out of your Nextel phone and service!

*Ever wish you could take your assistant with you? The i2000 phone has the right business solutions for you.*

Personalized 24-hour Voice Mail, which takes messages when you're not available and a whole lot more. (For details see "Nextel Voice Mail Service" on page 38.) And, Schedule a Page, which can help you remember those important dates by sending a text message directly to your phone (see "Web Paging" on page 65).

*Need an extra pair of hands to help juggle your hectic work load?*

The i2000 phone doesn't come with a pair of hands; but it does include the hands-free speakerphone feature! You can place a call and set the phone down--while you hold a conversation or conference call--and use your hands for more important things like signing paperwork, composing e-mail, etc. (For details see "Using Hands-Free Speakerphone" on page 35.)

*Ever head for a meeting and forget the company's address?*

Have your assistant send a text page to your i2000 phone. That's right, you can receive text and numeric pages right to your i2000 phone. (For details see "Text and Numeric Paging" on page 63.)

*Need to remind everyone on the committee you chair about an upcoming meeting?*

Create a Group List for any committee, project task force, etc. Then, create a voice message and send it to everyone in the group! It's just that simple with the i2000 phone. (For details see "Creating Group Lists" on page 51.)

*Holding conference calls has never been easier. Your i2000 phone includes 3-way calling.*

With 3-way calling, you can conduct a conference call with clients or co-workers whether you're in the office or on the go! (For details see "Three-Way Calling" on page 58.)

*Need to monitor phone call length for charging purposes?*

You can with the i2000 phone, just turn on the Display Timer and the duration of the most recent phone call will display. (For details see "Display Timer: On/Off" on page 89.)

*Responsible for keeping in touch with building maintenance workers or project team members?*

You can use your i2000 phone as a two-way radio for a fraction of the cost of cellular calls. (For details see "Nextel Direct Connect®" on page 75.)

## International Business Solutions

With the i2000 phone you can continue to conduct business--even when you travel overseas! Below is a list of solutions that will help you get the most out of your phone and Nextel service while traveling internationally.

*Does your job require traveling abroad?*

The i2000 phone with Nextel Worldwide Service allows you to increase your communication opportunities outside of the U.S., in places like Mexico, Asia, and Europe to name a few! Placing and receiving international calls has never been easier. Callers have one number to reach you at no matter where you travel on the Nextel National Network and Nextel Worldwide Service. In addition, the i2000 phone's international dialing function makes staying in touch simple. See "*Placing International Calls With Plus Dialing*" on page 34.

*After a long business trip out of the country, do you dread your return--knowing that dozens of new messages are waiting for you?*

The i2000 phone lets you retrieve your voice messages while you're traveling overseas--so returning home doesn't become an overwhelming event! See "*Listening to New Messages While Overseas*" on page 43 for more information.

*With all of the other details to remember when traveling abroad, wouldn't it be nice to have reminders prompt you about important dates?*

Well you've got it! With the i2000 phone you can have text pages sent directly to your phone at set dates and times with "Schedule a Page". See "*Web Paging*" on page 65.



---

# Getting Started

In this section, you will learn everything you need to know to begin using your *i2000* phone. This section also includes a Quick Guide portion so experienced digital phone and two-way radio users can get started right away.

## About This Section

This section includes instructions for the following tasks:

Batteries: Attaching, Detaching and Charging	Page 11
Turning Your <i>i2000</i> Phone On/Off	Page 13
Your Phone's SIM Card	Page 14
Activating Your <i>i2000</i> Phone	Page 20
<b>NOTE: Your phone must be activated before you can place or receive a call.</b>	
Your Nextel Phone Status	Page 21
Modes and Menus	Page 23
Quick Guide to <i>i2000</i> Phone Functions	Page 24

## Batteries

Your *i2000* phone comes with a standard Motorola iDEN Lithium Ion battery and a Motorola iDEN approved Lithium Ion battery charger. After attaching the battery, charge it (while the phone is off) for at least three hours before you use it for the first time. After the initial charging, the battery can be charged more quickly.

Remove the battery from the protective case provided in the original packaging. When the battery is not attached to the phone store it in this case.

## Attaching the Battery

- 1 Insert the top of the battery into the top of the battery area (located on the back of the phone) as shown in the picture.

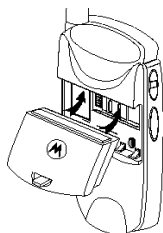

- 2 Press down on the bottom of the battery until you hear a click.

**NOTE:** The battery can be charged with the i2000 phone either turned on or off. For best results, charge it with the phone turned off.

## Detaching the Battery

- 1 If the phone is turned on, press  until the message **Powering Off** displays.
- 2 Press the latch on the battery cover upward and pull the battery outward and away from the phone.

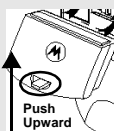

## Charging the Battery

**NOTE:** Before you use the battery for the first time, charge it for at least three hours. After the initial charging, the battery can be charged more quickly.

- 1 Make sure your i2000 phone is facing you.



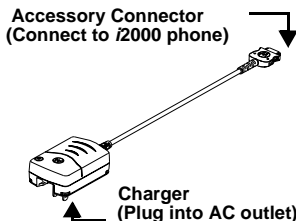

- 2 With the  logo on the accessory connector facing you, plug the accessory connector into the bottom of the i2000 phone.



- 3 Flip open the prongs and plug the charger into an AC outlet.

## Battery Charging Status



The battery strength indicator icon, found on your phone's display screen, shows the charge amount remaining in the battery.

					
	Icon Flashes	Icon Displays	Icon Displays	Icon Displays	Icon Displays
<b>Charge Strength</b>	<b>Low Battery</b>	<b>0-30%</b>	<b>31-60%</b>	<b>61-90%</b>	<b>91-100%</b> <b>Fully Charged</b>

A short, chirp-like sound indicates a low battery. The icon flashes when you have 5 minutes of talk time remaining.

## Turning Your i2000 Phone On/Off

### Phone On

1	Extend the antenna.
2	Press and hold  until the status light glows red.
3	When the <b>Enter SIM PIN</b> screen displays, enter your SIM PIN. (For more information see “SIM Card Personal Identification Number (PIN)” on page 14.)
4	Press  under “Ok”.
	As your phone connects to the Nextel National Network, you will see a <b>Welcome to Nextel</b> message and a connecting message. When <b>Phone Ready</b> appears on the display, you are ready to use your i2000 phone!
	<b>NOTE: When you are in the GSM service area, line 2 of the Phone Ready screen displays the name of the network providing GSM service; line 3 displays Nextel.</b>

### Phone Off

1	Press and hold  until you see the message <b>Powering Off</b> .
2	Push in the antenna.

## Your Phone's SIM Card

Your i2000 phone comes with a SIM (Subscriber Identity Module) card located in the "SIM Card Holder" on the back of the phone behind the battery. You can verify that the SIM card is in place by viewing the numbers on the SIM card through the SIM card holder.

**NOTE: If there is no SIM card present, notify your Nextel Authorized Representative immediately.**

The SIM card maintains all of the stored names, numbers, and the PIN you enter into your i2000 phone. Your SIM card must be in place to make or receive calls.

This section contains everything you need to know about your SIM card. However, to quickly begin using your phone you can refer to "*SIM Card Personal Identification Number (PIN)*" on page 14 and "*Entering the PIN*" on page 14. Then, proceed to "*Attaching the Battery*" on page 12 and read the remaining information at a later time.

## SIM Card Personal Identification Number (PIN)

To prevent unauthorized use of your phone, your SIM is protected by a PIN. Each time the i2000 phone is turned on, a PIN must be entered. You can later change or disable your PIN if desired.

**NOTE: Disabling your PIN enables anyone to use your phone. If you disable your PIN, you still must keep the SIM card in the phone to make calls.**

### Entering the PIN

By default your phone is automatically set to ask for a PIN.

**NOTE: Your default SIM card PIN is: 0000. It is recommended that you change your PIN to prevent fraudulent use of the SIM card (see "*Changing the PIN*" on page 15).**

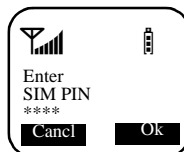











- 1 From the **Enter SIM PIN** screen, immediately enter your PIN digits. As you enter your PIN, an asterisk appears for each character entered.

**NOTE: You will not receive phone calls, etc. until you enter the PIN.**

- 2 Press  under "Ok".

If you enter an incorrect PIN, the message, **Wrong PIN** appears. After three consecutive incorrect attempts, even if you turn your phone off and on again, the SIM card blocks any additional tries. If this happens, see the following section titled "*Unlocking the PIN*" on page 16.)

## Changing the PIN



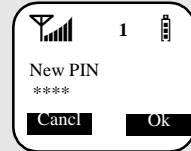
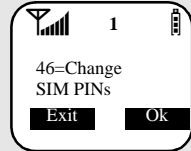

1	From the <b>Phone Ready</b> screen, press  until you see the “Prgm” menu option.
2	Press  under “Prgm”.
3	Press  then  .
4	Press  under “Ok”.
5	At the <b>Change PIN?</b> screen, press  under “Ok”.
6	At the <b>Old PIN</b> screen, enter your current PIN then press  under “Ok”.
7	At the <b>New PIN</b> screen, enter your new PIN then press  under “Ok”.
8	At the <b>Repeat New PIN</b> screen, enter your new PIN again then press  under “Ok”.
9	Press  under “Exit” to return to <b>Phone Ready</b> .

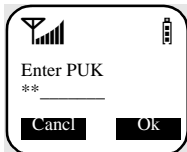

## Unlocking the PIN

If you forget your PIN and unsuccessfully enter it three times, access to your i2000 phone will be blocked. To unblock the PIN:



- 1 Call International Roaming Customer Care at 1(201) 531-5202 or Domestic Customer Care at 1(800) 639-6111 for your PIN Unlocking Key (PUK) code.
- 2 Press any key to display the **PIN Unlocking Key (PUK)** screen. Make sure no asterisks appear on the screen before you begin to enter the PUK digits.  
(To delete asterisk(s) press  until asterisk(s) are deleted.)
- 3 Enter your PIN Unlocking Key (PUK). As you enter it, the **Enter PUK** screen appears and an asterisk appears for each character. This prevents others from seeing your PUK. Immediately go to the next step.  
A screenshot of a mobile phone screen with a white background. At the top left is a signal strength indicator and at the top right is a battery level indicator. The text in the center reads "Enter PUK" followed by two asterisks and a horizontal line for input. At the bottom are two buttons labeled "Cancel" and "Ok".
- 4 Press  under "Ok".
- 5 At the **New PIN** screen, enter a new PIN (must be four to eight characters in length).  
A screenshot of a mobile phone screen with a white background. At the top left is a signal strength indicator and at the top right is a battery level indicator. The text in the center reads "New PIN" followed by two asterisks and a horizontal line for input. At the bottom are two buttons labeled "Cancel" and "Ok".
- 6 Press  under "Ok".
- 7 At the **Repeat New PIN** screen, enter the new PIN again.
- 8 Press  under "Ok".

**NOTE:** If you unsuccessfully enter the PUK number ten times, the SIM card is blocked. If this happens, you will get a message to call your service provider.

## Disabling the PIN Requirement

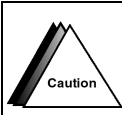

If you disable the PIN requirement, you remove protection of personal data on your SIM card. Anyone can then use your phone and access your personal data.

- 1 From the **Phone Ready** screen, press until you see the “Prgm” menu option.
- 2 Press under “Prgm”.
- 3 Press then . The **47=Require SIM PIN:On** screen displays, indicating that the PIN requirement is set.
- 4 Press under “Off”.
- 5 Enter your SIM PIN.
- 6 Press under “Ok”.
- 7 Press under “Exit”.

## Enabling the PIN Requirement

- 1 From the **Phone Ready** screen, press until you see the “Prgm” menu option.
- 2 Press under “Prgm”.
- 3 Press then . The **47=Require SIM PIN:Off** screen displays, indicating that the PIN requirement is off.
- 4 Press under “On”.
- 5 Enter your SIM PIN (Nextel provides the initial SIM Card PIN).

6 Press  under “Ok”.

7 Press  under “Exit”.

When the PIN is enabled, you are prompted to enter your PIN each time you turn on your *i2000* phone. Until a valid PIN is entered, you can use the phone only to make emergency calls depending on the network.

After the PIN is accepted, the **Phone Ready** screen displays.



**Incorrectly entering your PIN three times causes the phone to be blocked. To unblock your phone, you must contact Nextel Customer Care. For more information, see “Unblocking the PIN” on page 16.**

## Light Sensor

On your *i2000* phone, when a key is pressed, the light sensor will activate the backlight only when your phone is in poor lighting conditions. If illumination is needed, even when the backlight is disabled, you can manually override the sensor by pressing and holding the  key. This will activate the backlight. If the phone is in a charger, the backlight will always be illuminated.

## Keypad Lock

The *i2000* phone includes a Keypad Lock feature that enables you to quickly lock the phone’s keypad to avoid inadvertently pressing keys or placing calls. Once Keypad Lock is activated, you can only perform the following tasks (unless you receive an incoming call, page, etc.):

- Turn your phone On/Off
- Unlock the keypad

**NOTE:** Before locking your phone’s keypad, you may want to read this entire section to learn how to respond to incoming calls, pages, etc.

## Activating Keypad Lock

From the **Phone Ready** screen, simultaneously press **\*** and **#**. The message **Keypad Locked** displays on your phone.

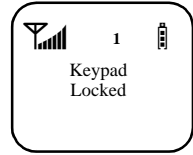

**NOTE:** Whenever a key is pressed, while in Keypad Lock mode, the Keypad Locked message displays as a reminder.

### Receiving Incoming Calls

When you receive an incoming phone call (see “*Phone Calls*” on page 31 for more details), keypad lock will be temporarily suspended. You may perform the following:

Press **☎** to answer the call. Or,

Press **⓪** under “End” to send the call to voice mail and reactivate keypad lock.

### Receiving New Mail Messages

When you receive a new mail message (see “*Notification of New Pages*” on page 63 for more information), the keypad lock will be temporarily suspended. You may perform the following:

Press **⓪** under “Later” to return to **Phone Ready** and reactivate the lock. Or,



Press **⓪** under “Now”. Press **⓪** under “Read”. Press **⓪** under “Save” or “Erase”. Once you have finished, press **⓪** under “Exit” to return to **Phone Ready** and reactivate the lock.

**NOTE:** If you have disabled the Message Mail Notification feature, only the  icon will display. You will not receive the Read Now/Later options.

## Receiving Voice Mail

When you receive a new voice mail (see “*New Message Indicators*” on page 39 for more information), keypad lock will be temporarily suspended. You may perform the following:

When **New Voice Mail Waiting** displays, press  under “Exit” to return to **Phone Ready** and reactivate the lock. Or,



Press  under “Dial” to access Voice Mail service. Once you have finished, press  to exit Voice Mail, return to **Phone Ready** and reactivate the lock.

**NOTE:** If you have disabled Voice Mail Notification,   will display, however, “**New Voice Mail Waiting**” will not appear.

## Receiving Nextel Direct Connect® Calls

When you receive an incoming Direct Connect call (see “*Nextel Direct Connect®*” on page 73 for additional information), the phone will automatically activate the applicable mode (i.e., Group, Private, etc.). Once the call is terminated and the Display Timer (see “*Display Timer: On/Off*” on page 87) has expired, the phone will return to **Phone Ready** and reactivate the lock.

## Deactivating Keypad Lock

From the **Phone Ready** screen, simultaneously press  and . The message **Keypad Unlocked** displays. Or,

Press  followed by  to unlock the keypad. The message **Keypad Unlocked** displays.

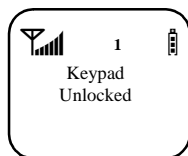

## Activating Your i2000 Phone

Before you can begin using your i2000 phone, it needs to be activated.

- If you purchased your phone through a Nextel Sales Representative, your phone should be active already.
- If there is a separate activation sheet in this package, simply follow the step-by-step instructions included.

If your display reads **No Service** or doesn't change to the **Phone Ready** screen when you turn on your phone, and you know you are in a Nextel coverage area, call Nextel Customer Care at 1-800-639-6111. When traveling overseas call 1 (201) 531-5202. This Customer Care number will be toll-free from your Nextel handset both domestically and internationally.

**NOTE:** To register for the first time on the Nextel network, you must turn on your i2000 phone in your local calling area.









## Your Nextel Phone Status

Your *i2000* phone has a “Status Light” indicator. The “Status Light” shows you, at a glance, the status of your connection (see Features Bookmark on inside cover).

Status Light Indicator	Nextel Phone Status
<b>Flashing Red</b>	Signing on to the network. Please wait.
<b>Solid Red</b>	No service or out of coverage area. If you are in a coverage area, keep your phone on and it will continue trying to connect every two minutes. If you cannot connect after 15 minutes, call Nextel Customer Care at 1-800-639-6111. When traveling overseas call 1 (201) 531-5202. This Customer Care number is toll-free from your Nextel handset both domestically and internationally.
<b>Flashing Green</b>	In service/Ready to use.  <b>NOTE: Nextel Direct Connect calls are not available outside of your home market area.</b>
<b>Solid Green</b>	In use.

## Display Icons



After you turn on your phone, the following icons may appear on the display:

	<b>Signal Strength Indicator:</b> Shows the signal strength. Six bars indicate the strongest signal. Calls and messages cannot be sent or received when there is no signal.
	<b>Battery Strength Indicator:</b> Shows the remaining charge in your battery.
	<b>Voice Mail Indicator:</b> Indicates that you have messages in your voice mailbox. A flashing voice mail icon indicates that you have new, unplayed messages.
	<b>New Text and Numeric Paging Flashing Indicator:</b> Indicates that you have new incoming pages.
	<b>Unread Text and Numeric Paging Indicator:</b> Indicates that you have unread but saved pages.
	<b>VibraCall™ Indicator:</b> Indicates that the Vibrate All option is turned on. Your i2000 phone will vibrate instead of emitting ring tones.
1 2	<b>Active Line Indicator:</b> Indicates the active phone line (1 or 2).
	<b>Call Forward Indicator:</b> Indicates that incoming phone calls have been forwarded for a specified line (1, 2, or both).
	<b>Private/Group Speaker Indicator:</b> Indicates that the Private/Group speaker is off. You will hear Nextel Direct Connect calls through the earpiece.

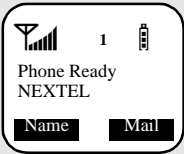
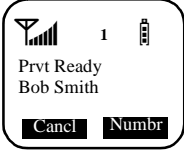

## Modes and Menus

When you first turn on your phone, the display defaults to **Phone** mode. However, your *i2000* phone operates in three different modes.

To switch between modes, press . The table below provides more details about the three modes:

Mode	What the Display Looks Like	Function
Phone Mode		To make cellular phone calls.
Private Mode		To make private two-way radio calls using Nextel Direct Connect.
Group Mode		To make group two-way radio calls using Nextel Direct Connect.

If the word **Ready** does not appear after the mode name in the display, that mode is either unavailable or it has not been activated. Once a mode is activated, there are various menu options (within each mode) that allow you to access different functions. To switch between menu options follow the steps below:

1	Press  .
2	Press  under the displayed menu option that you want to select.

## Quick Guide to i2000 Phone Functions

Now that you understand different modes, here's a quick way to get started using them. This Quick Guide highlights some of the most commonly used functions in **Phone**, **Private**, and **Group** modes. These functions are described in more detail in later sections.

### Phone Mode

You must be in **Phone** mode to perform the following functions:

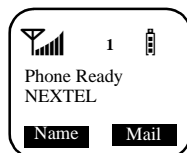

Function	Action
<b>Programming Your Own Phone Number</b>	<ol style="list-style-type: none"> <li>1 Press <b>HMENU</b> until you see "Prgm". Press <b>OK</b> under "Prgm" and enter <b>1</b>.</li> <li>2 Press <b>OK</b> under "Ok".</li> <li>3 Enter your phone number.</li> <li>4 Press <b>OK</b> under "Store".</li> <li>5 Press <b>OK</b> under "Exit".</li> </ol> <p><b>NOTE: Your phone number is automatically programmed when you receive your first call.</b></p>
<b>Displaying Your Phone Number</b>	<ol style="list-style-type: none"> <li>1 Press <b>HMENU</b> until you see "Prgm". Press <b>OK</b> under "Prgm".</li> <li>2 Press <b>1</b>.</li> <li>3 Press <b>OK</b> under "Exit".</li> </ol>
<b>Making a Phone Call</b>	Using the keypad, enter the desired number. Then press <b>CALL</b> .
<b>Ending a Phone Call</b>	Press <b>END</b> .
<b>Last Number Redial</b>	Press <b>CALL</b> .
<b>Emergency Dial</b>	Press and hold <b>911</b> for two seconds.
<b>Receiving a Phone Call</b>	Press <b>CALL</b> or any numeric key (0 through 9).

## Private Mode\*

You must be in **Private** mode to perform private two-way radio functions. Press  to switch from **Phone** to **Private** mode.



Function	Action
<b>Sending a Prvt Call</b>	<p>From the <b>Prvt Ready</b> mode, your most recently used Nextel Direct Connect call displays. To scroll other names, press . Select the name of the individual you would like to call or enter the Private ID number.</p> <p>To place the call, press and hold the Nextel Direct Connect Push-To-Talk button. Wait for the chirp, then speak into the microphone.</p> <p>To listen, release the Nextel Direct Connect Push-To-Talk button.</p>

\* This feature is only available in your home market area.

## Group Mode\*

You must be in **Group** mode to perform group two-way radio functions. Press  until you reach **Group** mode.



Function	Action
<b>Sending a Group Call</b>	<p>From the <b>Group Ready</b> mode, your most recently used talkgroup displays. To scroll other talkgroups, press .</p> <p>To place a call to a talkgroup, press and hold the Nextel Direct Connect Push-To-Talk (PTT) button. Wait for the chirp, then speak into the microphone.</p> <p>To listen, release the Nextel Direct Connect PTT button.</p>

\* This feature is only available in your home market area.

# Creating, Editing and Using Stored Lists

A stored list is made up of names, phone numbers, private IDs and speed dial numbers. Stored lists are convenient because you do not need to remember names and numbers. Instead, you simply scroll through your stored list, press a button and the number is dialed for you.

**NOTE: If you want to use your computer to create stored lists for your *i2000* phone, use Nextel's iDEN Organizer. It's available for programming names, phone numbers, and Private IDs into your phone. To order, call Nextel Nextday<sup>SM</sup> Accessories at 1-800-914-3240 or contact your Nextel Authorized Representative.**



**NOTE: You may want to read "Pause Digit Entry" on page 28 and "Plus Dialing" on page 35 before you create a stored list. Using Pause Digit Entry and Plus Dialing will enable you to create stored lists that will save time when placing calls.**

## About This Section















This section includes instructions for the following tasks:

Storing Names and Numbers	Page 26
Pause Digit Entry	Page 28
Editing Stored List Entries	Page 29

## Storing Names and Numbers

This programming function allows you to store up to 100 names, phone numbers and private ID numbers. Your *i2000* phone will automatically assign the next available speed dial number, which you can change. Once you have stored an individual, you can call them by scrolling through the list and finding their name, using the speed dial number or using Nextel Direct Connect (see "*Customizing the i2000 Phone*" on page 80). Whenever the person calls you, your phone will display their name if you entered their 10-digit phone number. The display holds 12 phone-number characters. If the phone number exceeds 12 characters, you can press  under "More" to see the remaining characters. To return to the start of the number, press  under "Numbr".

You can store up to 100 names, phone numbers and private IDs using the following steps:

- |   |   |
|---|---|
| 1 | Press  until you see the “Prgm” option.  |
| 2 | Press  under “Prgm”. Then press  then  .   |
| 3 | The message: <b>20=Phone / Prvt List</b> displays.<br><br>Press  under “Ok”. The next screen displays the remaining number of phone numbers and Private IDs that you can store. The phone will then display the <b>Enter Name</b> screen.  |
| 4 | Enter the name of the individual you want to store.<br><br>(Notice, each key has a number and several letters. To select different letters on a key, quickly press the key until the desired letter displays. For example, to enter the letter Y you must press the  key 3 times quickly. Also, you can press and hold  to change the case of the letter you just entered (lower to upper and upper to lower case). The default style is upper case.)<br><br><b>NOTE:</b> Press  to delete a letter. Press  to insert a space.<br>After you have entered the name, press  under “Store”. |
| 5 | <b>Enter Phone Number</b> displays. Enter the area and phone number. Also, you may use the Plus Dialing and/or Pause Digit Entry at this screen. Refer to “ <i>Pause Digit Entry</i> ” on page 28 and/or “ <i>Plus Dialing</i> ” on page 35.<br><br>Press  under “Store”.  |
| 6 | The <b>name and Spd# =</b> displays. The system automatically assigns a speed dial number, which you can change by entering a new number. Press  under “Store”.  |
| 7 | <b>Enter PrvtID</b> displays. Enter the person’s Direct Connect private ID. Press  under “Store”.  |
| 8 | Repeat steps 3 through 7 to add additional names/numbers.   |
| 9 | Press  under “Exit”.   |

## Pause Digit Entry

When storing a number, you can program your phone so that it will not only dial a number but also pause and enter another series of numbers such as a personal PIN or password. This feature is particularly useful for automated services such as voice mail and banking systems.

Here's how it works! Let's say you have a company voice mail account that you frequently check while on travel. And, to access that account you must do the following:

- Dial your work number;
- Press **#** while the voice mail greeting is being played; and
- Enter your personal PIN to access your messages.

You can program your *i2000* phone to enter all of the above information for you. All you have to do is separate each entry with a pause. If you were to program your phone to automatically input the above information, the stored data would look like this 17035551234P#P1234. In this example, the first eleven digits represent the number that must be dialed to access your voice mail. The P represents a 3 second pause. The **#** interrupts your greeting. The second P represents another 3 second pause. The last four digits represent your personal PIN.

You can use this feature not only to enter personal PINs and passwords but also to have the phone automatically select menu options (i.e., press 1 to hear messages).

To create a three-second pause follow the steps below:

Press and hold **\*** for two seconds. The pause symbol (P) will appear.











**NOTE:** You can enter up to 20 numbers/characters in a single entry, stored or dialed.

**NOTE:** If you use a system that will not let you enter an option until the automated message has played in its entirety, you can program your phone to pause for more than 3 seconds. For example, performing the above step twice will program two pauses and cause your phone to wait 6 seconds before entering the next set of numbers.











## Editing Stored List Entries

Once you have created lists, you can edit them as necessary. Select the applicable option below to edit a portion of a list.

### Edit a Phone Number or Associated Name or Speed Dial Number













1	Press  until you see the “Prgm” option.
2	Press  under “Prgm”. Press  then  .
3	At the <b>Phone List Edit</b> screen press  under “Ok”.
4	At the <b>Edit Entry?</b> screen, press  under “Ok”.
5	Press  until the desired entry appears. Press  under “Ok”.
6	Edit the desired information (Number, Name, Speed Dial Number) and press  under “Store”. If you do not wish to edit one or more of the components, just press  under “Ok”.
7	Press  under “Exit” until you see the <b>Phone Ready</b> screen.

### Editing a Private ID or Associated Name

1	Press  until you see “Prgm”.
2	Press  under “Prgm” and enter  then  .
3	Press  under “Ok”. The <b>Edit Entry?</b> screen displays.
4	Press  until the desired entry appears. Press  under “Ok”.
5	Edit the desired information (Private ID, Name) and press  under “Store”. If you do not wish to edit one or more of the components, just press  under “Store”.
6	Press  under “Exit” to close the <b>Private ID List Edit</b> screen.

## Erasing List Entries

Erasing stored list entries is as easy as creating them. To erase an entry item, follow the steps below:

1	Press  until you see the "Prgm" screen.
2	Press  under "Prgm" and enter  then  to erase a Phone entry (or  ,  to erase a Private ID entry).
3	At the <b>Phone</b> or ( <b>Prvt ID</b> ) <b>List Edit</b> screen, press  under "Ok".
4	Press  at the <b>Edit Entry?</b> screen until you see <b>Erase Entry?</b>
5	Press  under "Ok".
6	Press  until the desired entry appears.
7	Press  under "Ok".
8	Press  under "Yes" at the <b>Erase?</b> screen.
9	Press  under "Exit" until you see the <b>Phone Ready</b> screen.

---

# Phone Mode

## Phone Calls

In addition to making and receiving phone calls while in **Phone** mode, you can make emergency calls, be notified of a missed call, select ring style notification, set VibriCall, and more.



**NOTE:** For most Phone functions, you must be in **Phone Mode**. Press  until you see **Phone Ready**. For more information, see “Modes and Menu” on page 23.

## About This Section







This section includes the following:

Programming Your Own Phone Number	Page 31
Making Phone Calls	Page 32
Placing International Calls With Plus Dialing	Page 34
Using Hands-Free Speakerphone	Page 35
Receiving/Ending a Phone Call	Page 36
Missed Call Indicator	Page 36
Last 10 Numbers Received/Sent Call List	Page 37
Quickstore of Phone Numbers	Page 37

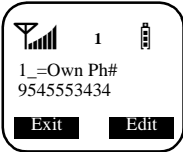



## Programming Your Own Phone Number

Before you get started using your *i2000* phone, you may need to enter your own phone number so you can refer to it later if necessary. This is a one-time activity that can be performed using the following instructions. Or, you can wait for your first incoming call, when it is automatically entered.

**NOTE:** If your Nextel phone has two lines, your phone number for the second line will not be automatically entered with the first incoming call to that line. You must manually program the number. First select the line for the phone number that you want to program, and then continue. For more information, see “Alternate Line Service (Unavailable on GSM)” on page 59.

<p>1 To store your phone number in your Nextel phone (or the alternate line, if you have two lines), press  until you see the “Prgm” menu option.</p>	
<p>2 Press  under “Prgm” and press .</p>	
<p>3 Press  under “Ok”. (After phone number is programmed, option will read “Edit”.)</p>	
<p>4 Enter your phone number.</p>	
<p>5 Press  under “Store”.</p>	
<p>6 Press  under “Exit” to return to the <b>Phone Ready</b> screen.</p>	



### Displaying Your Phone Number

<p>1 Press  until you see “Prgm”.</p>
<p>2 Press  under “Prgm”.</p>
<p>3 Press .</p>
<p>4 Press  under “Exit”.</p>



### Making Phone Calls

There are five ways to make a phone call: Direct Dial, Scroll, Name Search, Speed Dial, and Turbo Dial™.

#### Direct Dial

<p>1 From <b>Phone Ready</b>, enter the number using the keypad.</p>
<p>2 Press  to place the call.</p>
<p>3 Press  to end the call.</p>



If you make a mistake:

To Clear One Digit	To Clear All Digits	To Cancel
Press 	Press and hold 	Press  under "Cancl"



### Making Calls From the Stored List

Before you can use the Scroll, Name Search, Speed Dial or Turbo Dial methods, you first must create a phone list. To learn how to create stored lists, see Page 26.



#### Scroll

- 1 From **Phone Ready**, press  to select the individual you want to call.
- 2 Press .

#### Name Search

- 1 Press  under "Name".
- 2 Using the keypad, enter the first letter of the desired name.
- 3 Press  to scroll names, if necessary.
- 4 Press .

#### Speed Dial

- 1 Press  until you see the "Spd#" option.
- 2 Press  under "Spd#".
- 3 Enter the speed-dial number.
- 4 Press .

## Turbo Dial

Allows you to call any one of your first eight phone list entries by pressing and holding the corresponding numeric key (1-8).

## Automatic Redial

Press  to redial the last number you called.

**NOTE: If you receive “System Busy, Try Later”, press *e* to redial the number automatically. You will hear a ring-back tone when the call is successful.**

## Emergency/Non-Emergency Dial

The Emergency Dial feature allows you to call 911 emergency by pressing a single key.

**NOTE: If your keypad is locked, you must unlock it before pressing the emergency key.**

If you are on an active call, you must end it before pressing the emergency key.

Your phone is already programmed with the Non-Emergency number provided by your local State Police and Highway Patrol. You can use this feature to report traffic accidents, motorist problems, careless drivers or any other non-emergency highway incident.

Emergency:	Non-Emergency:
Press and hold  until the phone displays “EMERGENCY”.	Check <a href="http://www.nextel.com">www.nextel.com</a> for an up-to-date list of current numbers.

**NOTE: Access to 911 may not be available in all areas. Contact Customer Care at 1-800-639-6111. When traveling overseas call 1 (201) 531-5202. This Customer Care number will be toll-free from your Nextel handset both domestically and internationally.**

## Placing International Calls With Plus Dialing

Placing international calls has never been easier. The *i2000* phone and Nextel Worldwide Service includes access to multiple networks so you can get connected and stay connected.

When dialing internationally, you can either enter the international access code directly or use “Plus Dialing”. To place an international call using the “Plus Dialing” feature, see the following section.

### Plus Dialing

This feature enables you to quickly place an international call without entering the local international access code.

- 1 Press and hold **0+** for two seconds. A “0” appears, then changes to a “+”.

**NOTE: The network translates the “+” into the appropriate international access code needed to place the call.**

- 2 Enter the country code and phone number.

- 3 Press .

### Using Hands-Free Speakerphone

The *i2000* phone provides the convenience of a hands-free speakerphone for holding impromptu meetings or listening to your voice mail messages.

During speakerphone operation, you may either speak or listen, but you cannot do both at the same time. To use the speakerphone:

- 1 From **Phone Ready**, enter the number you want to call.

- 2 Press  to place the call.

- 3 Press  under “Spkr”. The “Spkr” option flashes while the speakerphone is on. Or,

Press  while on a phone call.



- 4 Place the phone 15-30 inches (380-760 millimeters) away from you. In a noisy environment, you may want to move the *i2000* phone closer to you for improved audio clarity.

### Turning Mute On/Off

If there is background noise in your area, you may have difficulty hearing a caller’s voice or messages. Muting the phone, which places you in “listen only” mode, may resolve this problem.

## Mute On

While on an active call:



- 1 Press  under “Spkr”. The “Spkr” option flashes while the speaker-phone is on.
- 2 Press  under “Mute”. The display changes from **Phone In Use** to **Phone —Mute**.

## Mute Off

While the microphone is muted, you can hear incoming audio, but a caller cannot hear you speak. You must turn “Mute” off to speak.

Press  under “Mute”. The display changes from **Phone Mute** to **Phone In Use**, indicating that the microphone is on.

## Receiving/Ending a Phone Call

An incoming call is indicated by a ring, vibration or backlight illumination. You can answer the call by pressing any numeric key (0-9), or by pressing , , or .

### Ending a Call



Press  to hang up.

## Missed Call Indicator

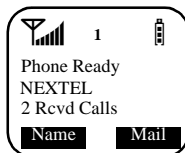
Your i2000 phone notifies you of unanswered phone calls. If you subscribe to Caller ID (and it is available in your area), your i2000 phone temporarily stores the caller’s phone number in your Last 10 Received Calls list. Your screen displays a flashing message with the number of missed calls. Press any key to clear the flashing indicator.



### Retrieving Missed Calls

- 1 Press  until you see the “Calls” option.
- 2 Press  under “Calls”.
- 3 Use  to continue viewing the list. The phone displays calls received from newest to oldest.

## Last 10 Numbers Received/Sent Call List



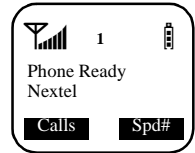



If you subscribe to Caller ID (and it is available in your area), you can view, dial, and store the last ten received and last ten sent telephone numbers. The most recently received or sent call appears first in your call list. If the name is not stored, only the phone number displays.









## Quickstore of Phone Numbers

Quickstore allows you to quickly store a received or sent phone number without going through the Programming menu.

### Reviewing/Storing Received Calls

1	Press  until you see the "Calls" menu option.
2	Press  under "Calls". The <b>Rcvd Calls</b> screen opens.
3	Press  to scroll entries. Press  under "Store" to store the number in the first available storage space.
4	Enter the name using the keypad. (Notice, each key has a number and several letters. To select different letters on a key, quickly press the key until the desired letter displays. For example, to enter the letter Y you must press the  key 3 times quickly.)
5	Press  under "Store" after you have entered the name.
6	Press  under "Cancel" to close the <b>Rcvd Calls</b> screen.

### Reviewing/Storing Sent Calls

1	Press  until you see the "Calls" option.
2	Press  under "Calls".
3	Press  until you see the "Sent" option, if this option isn't already visible.
4	Press  under "Sent".
5	Press  to scroll entries. (To store an entry from the Sent list press  under "Store" and follow steps 4-6 in the previous section titled "Reviewing/Storing Received Calls").

## Nextel Voice Mail Service

Welcome to Nextel's Voice Mail Service, a flexible, easy-to-use system that takes messages when you're not available--so you never miss an important call!

### About This Section

The main topics covered in this section are listed below:

Voice Mail Features: Basic	Page 38
Setting Up Your Voice Mailbox from Within the U.S.	Page 39
New Message Indicators	Page 39
About Voice Mail Menus	Page 40
Logging Into Voice Mail	Page 40
Listening Options (Quick Reference List)	Page 42
Listening to New Messages While Overseas	Page 43
Saving/Deleting Messages	Page 43
Choosing Order to Play Unheard Messages	Page 44
Customizing Your Voice Mail Setup	Page 44
Voice Mail Features: Advanced	Page 47

### Voice Mail Features: Basic

This section covers the most commonly used voice mail features. Once you log into voice mail, there are a number of innovative features you can access. They are also covered in this chapter. After you access Voice Mail, an automated system tells you each menu option and which button to press to make a menu selection.

## Setting Up Your Voice Mailbox from Within the U.S.

You must set up your voice mailbox before you can retrieve messages. The following steps will tell you how to setup your mailbox. However, before proceeding you may want to read *“Recording Your Active Greeting”* on page 45, which provides information you may want to include in your greeting:

1	Using your Nextel phone, dial your 10-digit Nextel Personal Telephone Number (PTN).  If you are calling from a phone other than your Nextel i2000 phone, dial your 10-digit Nextel Personal Telephone Number (PTN). When you hear the greeting, press * to access your voice mail account.
2	When prompted, enter your password. (New users should enter the last seven digits of your phone number. This is your temporary password).
3	Follow the tutorial to: <ul style="list-style-type: none"> <li>• Create a new four- to seven-digit password (see <i>“Changing Your Password”</i> on page 44).</li> <li>• Record your name (see <i>“Recording Your Name”</i> on page 45).</li> <li>• Record a greeting (see <i>“Recording Your Active Greeting”</i> on page 45).</li> </ul>
4	When the system says, “Enjoy using Nextel Voice Mail,” your mailbox is set up.

## New Message Indicators

When you receive a new message, the following will occur:

- **New Voice Mail Waiting** will display on the screen once your phone is turned on (if your phone is off when the call is received).

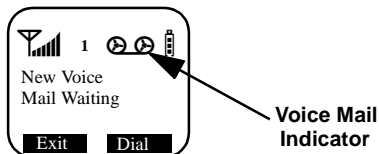

- The  icon will flash at the top of the display.
- Your i2000 phone will alert you every 30 seconds of new Voice Mail messages.

### About Voice Mail Menus

You are at the main Voice Mail screen when you hear the options listed below. If you press **#** while you are at a sub-menu, the system will say, “Invalid entry, please try again.” At that point, press the **\*** key until you hear the below options, indicating that you are at the main Voice Mail menu:

- To play your messages press **1** (this option plays only if you have new or saved messages)
- To record a Message press **2 abc**
- To change your Greeting press **3 def**
- To access your Personal Options press **4 ghi**
- To modify your Constant Touch Options press **5 jkl**

From the main Voice Mail menu, press **#** to exit Voice Mail. At any time, of course, you may simply hang up.

### Logging Into Voice Mail

To play new messages, you can set your Voice Mail options to Normal or Automatic Playback. By default, your voice mail is set to Normal. In this mode, after you log into your account, the system gives you a list of options. To listen to new messages you must select the appropriate option. After each message the system gives you another list of options. These options enable you to tell the system what to do with each message (i.e., save, delete, etc.). If you activate Nextel’s Automatic Playback feature, however, the system will automatically play and save new messages (see “Automatic Playback” on page 46).

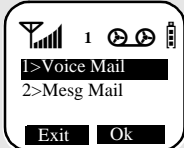
<p><b>1</b> Turn on your phone and wait for the screen to display <b>Phone Ready</b>. (See “Modes and Menus” on page 23 for additional information.)</p> <p>If you are calling from a phone other than your Nextel i2000 phone, dial your ten-digit Nextel i2000 phone number. When you hear Nextel’s Welcome greeting, press <b>*</b> to access your voice mail account, then skip to step 6 below.</p>	 <p>Phone Ready Nextel</p> <p><b>Name</b> <b>Mail</b></p>
<p><b>2</b> Press <b>2</b> under “Mail” to open the <b>Mail</b> screen.</p>	
<p><b>3</b> <b>Voice Mail</b> should be highlighted to indicate that it is selected. If it isn’t selected, press <b>1</b> to select it. An asterisk indicates new messages.</p>	 <p><b>1&gt;Voice Mail</b> <b>2&gt;Msg Mail</b></p> <p><b>Exit</b> <b>Ok</b></p>

- 4 Press  under “Ok.” The **Voice Mail** screen appears.

Notice, the screen displays the number of new messages and the total number of messages in the system—including saved and those in preparation (see “*Voice Mail Features: Advanced*” on page 47 for information on “in preparation” messages). An exclamation point (!) indicates an urgent message.

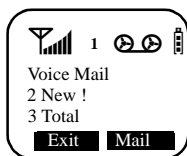

- 5 Press  under “Dial” to log into Nextel’s Voice Mail System. **Phone-In Use** displays as you are connected to the network.

- 6 When prompted, enter your password.

- 7 Proceed as desired, then exit Voice Mail (see “*About Voice Mail Menus*” on page 40) or hang up to end the call.

**NOTE:** You must receive a message before you can access voice mail from your i2000 phone. (Tip: You can leave yourself a message.)



### Listening Options

With Nextel’s Voice Mail Service you can listen to messages either immediately or later (also see “*Listening Options (Quick Reference List)*” on page 42). Select an option below and follow the steps:

#### Listen Now

- 1 Press  under “Dial”.
- 2 When prompted, enter password.
- 3 Follow the tutorial.

#### Listen Later

- 1 Press  under “Exit”.
- Though the   stops flashing, it remains on the screen as a reminder.
- When you are ready to listen to your messages, follow the steps in the section titled “*Logging Into Voice Mail*” on page 40.

### Listening Options (Quick Reference List)

After you access the Nextel Voice Mail Service (see “Logging Into Voice Mail” on page 40 and follow steps 1 through 6 to access voice mail) you have several options. The following information tells you what those options are and when you can use them.

Options available when selecting messages to be played:

Play new, unheard messages only.	Press <b>1</b> then <b>1</b>
----------------------------------	------------------------------

Options available while listening to your messages:

Replay previous six seconds.	Press <b>1</b>
Rewind to beginning of message.	Press <b>1</b> then <b>1</b>
Pause/continue the current message.	Press <b>2 abc</b>
Fast forward 6 seconds.	Press <b>3 def</b>
Fast forward to end of message.	Press <b>3 def</b> then <b>3 def</b>
Play the date and time stamp.	Press <b>5 jkl</b> then <b>5 jkl</b>

Options available while message is playing or after it has played:

Copy a message to another subscriber. (See “Voice Mail Features: Advanced” on page 47.)	Press <b>6 mno</b>
Delete the message.	Press <b>7pqrs</b>
Reply to a message.	Press <b>8 tuv</b>
Save the message.	Press <b>9 wxyz</b>
Skip to the next message.	Press <b>#</b>
Recover all deleted messages in that session.	Press <b>* * *</b> then <b>3 def</b>
<p><b>NOTE: Once you end a call, all messages will be deleted and cannot be retrieved.</b></p>	

## Listening to New Messages While Overseas

1	From the <b>Phone Ready</b> screen, press <b>1</b> under “Mail” to open the <b>Mail</b> screen.
2	<b>Voice Mail</b> should be highlighted to indicate that it is selected. If it isn’t selected, press <b>1</b> to select it. An asterisk indicates new messages. 
3	Press <b>1</b> under “Ok.” The <b>Voice Mail</b> screen appears.
4	Press <b>1</b> under “Dial”. <p><b>NOTE: If you hear a message that says, “Enter the phone number of the subscriber you are trying to reach” enter your own i2000 phone number.</b></p>
5	When the greeting plays, press <b>*</b> to interrupt it.
6	When prompted, enter password.
7	Follow the instructions.

## Saving/Deleting Messages

While a message is playing or, after you have finished listening to it, you can save it or delete it. To save a message press **9** when prompted to do so. To delete a message press **7** when prompted to do so (see “Automatic Playback” on page 46 to have messages automatically saved).

**NOTE: To retrieve deleted messages, press **\*** then **3** from the main Voice Mail menu. Messages that are not saved or deleted remain in your mailbox as new messages for 30 days. All messages are automatically deleted after 30 days.**

	<p>After exiting the voice mail session, you cannot recover deleted messages.</p>
---	---

## Choosing Order to Play Unheard Messages

With Nextel Voice Mail service, you can select the order you want unheard messages to be played in. You may listen to the last received message first. Or, you may listen to the first received message first. To select the order new messages should be played in, follow the steps below:

1	Log into Voice Mail. (See “ <i>Logging Into Voice Mail</i> ” on page 40.)
2	Press <b>4 ghl</b> to access Personal Options Menu.
3	Press <b>4 ghl</b> to access Personal Preferences.
4	Press <b>2 abc</b> to access Playback Preferences.
5	Press <b>1</b> to select preference. Follow the prompts until you have set your desired preferences.
6	Exit Voice Mail (see “ <i>About Voice Mail Menus</i> ” on page 40) or hang up to end the call.

## Customizing Your Voice Mail Setup

### Changing Your Password

To change your current password follow the steps below:

1	Log into voice mail (see “ <i>Logging Into Voice Mail</i> ” on page 40 and follow steps 1 through 6).
2	Press <b>4 ghl</b> to access Personal Options.
3	Press <b>4 ghl</b> to access Personal Preferences.
4	Press <b>1</b> to modify password.
5	Enter your new password (four- to seven digits).
6	Exit Voice Mail (see “ <i>About Voice Mail Menus</i> ” on page 40) or hang up to end the call.



For security purposes, it is recommended that you do not choose sequential or repeated digits like 1-2-3-4 or 5-5-5-5 for your password.

## Recording Your Name

When you send, reply to, or copy a message your name response precedes the message. To record or rerecord your name at any time use the following steps:

1	Log into voice mail. (see “Logging Into Voice Mail” on page 40 and follow steps 1 through 6).
2	Press <b>4</b> <small>ghi</small> to access Personal Options.
3	Press <b>4</b> <small>ghi</small> to access Personal Preferences.
4	Press <b>3</b> <small>def</small> to access the Record Your Name option.
5	Press <b>2</b> <small>abc</small> to record your name.
6	Exit Voice Mail (see “About Voice Mail Menus” on page 40) or hang up to end the call.

## Recording Your Active Greeting

**NOTE:** Through the Nextel Voice Mail Service, there are a number of ways people can reach you. You may want to include one or all of the following options in your greeting so that callers will know they are available. Also, in your greeting, you should tell callers to press the pound sign (#) after they have finished recording. This will prompt Voice Mail Service to play the list of menu options shown below:

- Press **1** to send a numeric page.
- Press **2** abc to send an operator assisted message. (This option is available only if you are a subscriber of Operator Assisted Paging. Contact Nextel Customer Care for more information.)
- Press **9** wxyz for other options (after pressing **9** wxyz the caller will need to press **5** ijkl for Delivery Options, which enables them to mark the message as Urgent, Private, etc.).
- Press **#** to skip the greeting and record message immediately.

## Sample Greeting

Below is a sample greeting. You can add the above options as you see fit.

“Hello, you’ve reached \_\_\_\_\_. I’m sorry I missed your call. If you leave a message at the tone, I’ll return your call as soon as possible. If you would like to bypass this greeting in the future, press pound. Thank you for calling.”

To record or alter your greeting at any time follow the steps below:

1	Log into voice mail (see “ <i>Logging Into Voice Mail</i> ” on page 40 and follow steps 1 through 6).
2	Press <b>3<sup>def</sup></b> to change your Greeting.
3	Press <b>1</b> to play, <b>2<sup>abc</sup></b> to record, or <b>3<sup>def</sup></b> to delete your active greeting.
4	Record your message and press <b>#</b> when you have finished.
5	Exit Voice Mail (see “ <i>About Voice Mail Menus</i> ” on page 40) or hang up to end the call.

### *Automatic Playback*

By default, the playback mode of your Voice Mail Service is set to Normal. Nextel’s Automatic Playback feature prompts the Voice Mail Service to automatically play and save new messages, which saves you time and money. To activate Automatic Playback follow the steps below:

1	Log into voice mail (see “ <i>Logging Into Voice Mail</i> ” on page 40 and follow steps 1 through 6).
2	Press <b>4<sup>ghi</sup></b> to access Personal Options.
3	Press <b>4<sup>ghi</sup></b> to access Personal Preferences.
4	Press <b>2<sup>abc</sup></b> to access Playback Preferences.
5	Press <b>2<sup>abc</sup></b> and select Automatic Playback.
6	Exit Voice Mail (see “ <i>About Voice Mail Menus</i> ” on page 40) or hang up to end the call.

**NOTE: You can deactivate Automatic Playback (after it has been activated) by following the above steps.**

## Voice Mail Features: Advanced

### Recording and Sending A Message

These functions allow you to record and send, reply to, or copy a message to a mailbox number, a name in the Voice Mail Service directory, or a Group List number, to an assigned destination address. After you record a message, the following sending options are available:

**NOTE: If you record a complete or partial message—but do not send it, Voice Mail Service will refer to this message as an “in preparation” message. (Before sending messages you may want to See “Special Delivery Options” on page 48)**

### Using Mailbox Numbers

To send a message to another mailbox, enter the mailbox number (10-digit telephone number) of the Nextel customer. The name response of the recipient plays if it is recorded.

### Using Group Lists

Enter the one- or two-digit Group List Number. You must have previously created this list. (See “Working With Group Lists” on page 50.)

To record and send a message, proceed to the table below:

1	Log into voice mail (see “Logging Into Voice Mail” on page 40 and follow steps 1 through 6).
2	Press <b>2<sup>abc</sup></b> to record a message.
3	Record your message and press <b>#</b> to end the message.
4	Press <b>9<sup>WXYZ</sup></b> at the prompt to indicate that you want to send the message.
5	Enter the mailbox number and/or group list number(s).
6	Press <b>#</b> to send.
7	Exit Voice Mail (see “About Voice Mail Menus” on page 40) or hang up to end the call.

## Special Delivery Options

After you have created a message, you can assign the message to a category before you send it. Below is a list of the categories that can be applied to a message:

<b>Urgent</b>	Recipient will hear this message before other messages.
<b>Private</b>	Recipient cannot copy the message to another mailbox or phone number.
<b>Notification of Non-Delivery</b>	You will be notified if the recipient has not listened to your message by a certain date and time.
<b>Future Delivery</b>	You can specify a specified time and date (up to three months in advance) for the message to be delivered.  Important: Once a message has been sent for future delivery, it cannot be retrieved or deleted.

To set a special delivery option, follow the steps below:

<b>1</b>	Log into voice mail (see “ <i>Logging Into Voice Mail</i> ” on page 40).
<b>2</b>	Press <b>2 abc</b> to record a message.
<b>3</b>	Record your message and press <b>#</b> when you have finished recording.
<b>4</b>	Press <b>5 jkl</b> for delivery options.
<b>5</b>	Press the number that corresponds with the desired delivery option: <ul style="list-style-type: none"> <li>• Press <b>1</b> for Urgent</li> <li>• Press <b>2 abc</b> for Private</li> <li>• Press <b>3 def</b> for Notification of Non-Delivery. At prompt, specify time.</li> <li>• Press <b>4 ghi</b> for Future Delivery of Messages. At prompt, specify time.</li> <li>• Press <b>9 wxyz</b> to send the message immediately</li> </ul>
<b>6</b>	Another list of options will be presented. Select the desired option.
<b>7</b>	Enter the destination mailbox or group number of the recipient(s).
<b>8</b>	Press <b>#</b> to send.
<b>9</b>	Exit Voice Mail (see “ <i>About Voice Mail Menus</i> ” on page 40) or hang up to end the call.

## Greetings Schedule

Nextel Voice Mail allows you to record up to five separate greetings that can be played based on pre-determined time frames. After you have recorded a greeting for each time frame, you can then select any of those greetings as your active greeting (see the following table). For example, if you activate the greeting schedule after you record Morning and Afternoon Greetings, the system will automatically play greetings 2 and 3 at the appropriate times. See the list of pre-determined schedules--then refer to the steps in the following table to record your greetings:

<b>Greeting 1</b>	Generic Greeting	24 hours a day/7 days a week. (This is the default setting if you haven't activated your greeting schedule.)
<b>Greeting 2</b>	Morning Greeting	7:30 a.m. -- 11:59 a.m. Monday -- Friday
<b>Greeting 3</b>	Afternoon Greeting	Noon -- 6:00 p.m. Monday -- Friday
<b>Greeting 4</b>	All Hours	24 hours a day/7 days a week
<b>Greeting 5</b>	All Hours	24 hours a day/7 days a week

To record your greetings, follow the steps below:

<b>1</b>	Log into voice mail (see <i>"Logging Into Voice Mail"</i> on page 40).
<b>2</b>	Press <b>3<sup>def</sup></b> to reach the Greetings menu.
<b>3</b>	Press <b>4<sup>ghi</sup></b> to modify another greeting.
<b>4</b>	Enter the greeting number you wish to create or modify.
<b>5</b>	Press <b>2<sup>abc</sup></b> to record a greeting.
<b>6</b>	Record your greeting and press <b>#</b> when you have finished.
<b>7</b>	Exit Voice Mail (see <i>"About Voice Mail Menus"</i> on page 40) or hang up to end the call.

## Activating Your Greeting Schedule

To activate your greeting schedule according to the pre-determined time frames (Morning, Afternoon, etc.) follow the steps below:

1	Log into voice mail (see “ <i>Logging Into Voice Mail</i> ” on page 40).
2	Press <b>3</b> <small>def</small> to reach the Greetings menu.
3	Press <b>9</b> <small>wxyz</small> to activate your greeting schedule.
4	Exit Voice Mail (see “ <i>About Voice Mail Menus</i> ” on page 40) or hang up to end the call.

## Working With Group Lists

The Group List feature enables you to create a list and assign it a unique name. Then, you can add mailbox numbers, group lists or individuals--by name--to the list. Once you create a list you can send a voice message to everyone on the list by simply entering the group list number. You can have up to 40 group lists. Each list can hold up to 50 addresses (see “*Using Group Lists*” on page 47).

## Creating Group Lists

To set up a Group List follow the steps below:

1	Log into voice mail (see “ <i>Logging Into Voice Mail</i> ” on page 40).
2	Press <b>4</b> <small>ghl</small> to modify another greeting.
3	Press <b>2</b> <small>abc</small> to access your Group Lists.
4	Press <b>2</b> <small>abc</small> to create a Group List.
5	Enter the one- or two-digit group list number and press <b>#</b> .
6	Record a name for the list and press <b>#</b> .
7	Select group members by mailbox number, group list, or name.
8	Press <b>#</b> to save all entries added to the list.
9	Exit Voice Mail (see “ <i>About Voice Mail Menus</i> ” on page 40).

---

## Modifying a Group List

1	Log into voice mail (see “ <i>Logging Into Voice Mail</i> ” on page 40).
2	Press <b>4<sup>ghi</sup></b> to access Personal Options.
3	Press <b>2<sup>abc</sup></b> to access Group Lists.
4	Press <b>4<sup>ghi</sup></b> to modify a Group List.
5	Enter the number of the Group List you want to modify.
6	Press <b>1</b> to add a new recipient.
7	Press <b>#</b> to save your changes.
8	Exit Voice Mail (see “ <i>About Voice Mail Menus</i> ” on page 40) or hang up to end the call.

## Deleting a Group List

1	Log into voice mail (see “ <i>Logging Into Voice Mail</i> ” on page 40).
2	Press <b>4<sup>ghi</sup></b> to access Personal Options.
3	Press <b>2<sup>abc</sup></b> to access Group Lists.
4	Press <b>3<sup>def</sup></b> to delete a group list.
5	Enter the number of the Group List you want to delete. The system will play the name of the group list.
6	Press <b>#</b> to delete the list.
7	Exit Voice Mail (see “ <i>About Voice Mail Menus</i> ” on page 40) or hang up to end the call.

## Message Forwarding

This feature allows you to program your phone to automatically forward incoming messages to another mailbox. There are three types of forwarding: Immediate, Silent and Delayed. They are discussed below:

- **Immediate Forwarding** - Caller is notified that the message will be forwarded.
- **Silent Forwarding** - Caller is not notified that the message will be forwarded.
- **Delayed Forwarding** - If a caller's message is not retrieved after a certain amount of time, the message will automatically be forwarded to another mailbox or telephone number.

### Create/Modify Message Forwarding Number

<b>1</b>	Log into voice mail (see <i>"Logging Into Voice Mail" on page 40</i> ).
<b>2</b>	Press <b>4</b> <small>ghl</small> to access Personal Options.
<b>3</b>	Press <b>5</b> <small>jkl</small> to modify Forwarding Options.
<b>4</b>	Select the applicable option below: <ul style="list-style-type: none"> <li>• To create a forwarding number, press <b>2</b> <small>abc</small>.</li> <li>• If you have already created a forwarding number, press <b>2</b> <small>abc</small> to modify the number.</li> </ul>
<b>5</b>	Exit Voice Mail (see <i>"About Voice Mail Menus" on page 40</i> ) or hang up to end the call.

### Enabling/Disabling Message Forwarding

<b>1</b>	Log into voice mail ( <i>"Logging Into Voice Mail" on page 40</i> and follow steps 1 through 6).
<b>2</b>	Press <b>4</b> <small>ghl</small> to access Personal Options.
<b>3</b>	Press <b>5</b> <small>jkl</small> to modify Forwarding Options.
<b>4</b>	Select the applicable option: <ul style="list-style-type: none"> <li>• If Message Forwarding is disabled, press <b>3</b> <small>def</small> to enable it.</li> <li>• If Message Forwarding is enabled, press <b>3</b> <small>def</small> to disable it.</li> </ul>
<b>5</b>	Exit Voice Mail (see <i>"About Voice Mail Menus" on page 40</i> ) or hang up to end the call.

## Modify Forwarding Type

1	Log into voice mail (see “ <i>Logging Into Voice Mail</i> ” on page 40).
2	Press <b>4</b> <sup>ghl</sup> to access Personal Options.
3	Press <b>5</b> <sup>jkl</sup> to modify Forwarding Options.
4	Press <b>4</b> <sup>ghi</sup> to modify Forwarding Type.
5	Select one of the following options: <ul style="list-style-type: none"> <li>• <b>1</b> for Immediate Forwarding</li> <li>• <b>2</b><sup>abc</sup> for Silent Forwarding</li> <li>• <b>3</b><sup>def</sup> for Delayed Forwarding</li> </ul>
6	Exit Voice Mail (see “ <i>About Voice Mail Menus</i> ” on page 40) or hang up to end the call.

## Time and Date Charts

Time and Date Charts can be referenced for specific tasks throughout the Voice Mail System.

### Voice Mail 24-hour Military Time Clock

The voice mail service uses military time, also referred to as the 24-hour clock:

**NOTE: To compute the 24-hour clock for p.m. time add 1200 to the a.m. time. For example, 2:00 p.m. is 1400 hours in military time (0200 + 1200 = 1400).**

Below is a list of hours translated into military time:

Hour	12:00 am	4:00 am	8:00 am	12:00 pm	4:00 pm	10:00 pm
Military Time	0000	0400	0800	1200	1600	2200

## Dates

All dates must have 4 digits in the MM/DD format (2 digits for the month and 2 digits for the day). January is 01, February is 02, etc. The first day of the month is 01, the second day of the month is 02, etc.

## Pager Notification

If you have purchased a pager and you would like your pager to notify you of incoming messages to your *i2000* phone when it is turned off, you can activate this feature. To do so, call Nextel Customer Care at 1-800-639-6111 or dial 611 from your Nextel phone.

## Enabling/Disabling Pager Notification

1	Log into voice mail (see <i>“Logging Into Voice Mail”</i> on page 40 and follow steps 1 through 6).
2	Press <b>4 ghl</b> to access Personal Options.
3	Press <b>3 def</b> to change Pager Notification Options.
4	Select the applicable option below: <ul style="list-style-type: none"> <li>• If Pager Notification is enabled press <b>3 def</b> to disable it.</li> <li>• If Pager Notification is disabled press <b>3 def</b> to enable it.</li> </ul> Press <b>4 ghl</b> to enable notification of urgent messages only.
5	Exit Voice Mail (see <i>“About Voice Mail Menus”</i> on page 40) or hang up to end the call.

## Limiting Notification to Specific Times

This feature allows you to choose the hours you want the Pager Notification feature to be enabled. By default, it is enabled for 24-hours a day. However, you can change this. For example, you can select to be paged between 8:00 a.m. and 5:00 p.m. only. This enables you to control the time frame Pager Notification will be activated. If a call comes in after 5:00 pm, you will not be paged until 8:00 am the next morning. (Before using this option, you may want to refer to *“Time and Date Charts”* on page 53 since the phone will only accept times in a 24-hour clock format.)

1	Log into voice mail (see <i>“Logging Into Voice Mail”</i> on page 40 and follow steps 1 through 6).
2	Press <b>4 ghl</b> to access Personal Options.
3	Press <b>3 def</b> to change pager notification options.
4	Press <b>5 jkl</b> to modify your notification time window.
5	Enter the starting and ending times for your time window.
6	Exit Voice Mail (see <i>“About Voice Mail Menus”</i> on page 40) or hang up to end the call.

---

## Additional Phone Services

Nextel offers a variety of services to help you better manage your business and personal calls. Call Nextel Customer Care for additional information on phone services.

**NOTE: Some of these features may not be available while using Nextel Worldwide Service.**

### About This Section

This section includes:

Call Waiting	Page 55
Call Hold	Page 56
Three-Way Calling	Page 57
Call Forwarding	Page 57
Transferring Calls to Voice Mail	Page 58
Caller ID	Page 58
Alternate Line Service	Page 59

### Call Waiting

Call Waiting allows you to receive a second call while you are talking on the phone. With the *i2000* phone you can switch between calls so you never have to miss a call. By default, Call Waiting is always ON unless you turn it OFF for a specific call.

If you're on a call and you receive a second call, you will:

- **Hear** a tone; and
- **See** a message on your display informing you of another incoming call.

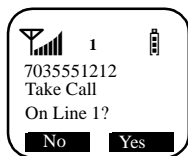

At that point, select one of the following options and follow the related instructions.

**NOTE: If your phone is activated with two lines and you select the Call Waiting option for one line, the alternate line is automatically changed.**

### Accept Call

Press  under "Yes".

## Decline Call

Press  under “No”. If you’re a Nextel Voice Mail customer, the call will be forwarded to your Nextel Voice Mailbox.

## Switching Between Calls



Press  under “Hold”. Your phone will refer to the first call as Call-1 and the second call as Call-2. If call 1 is on hold your display will read:  
**Call 1 - Hold 7035551234.**

## Ending the Active Call

Press .



## Turning Off Call Waiting

If you do not want to be interrupted during a call, you can turn Call Waiting off prior to making/receiving a call.



- 1 Press  until you see “Wait”, then press .
- 2 Press  under “Off”. Call Waiting will be disabled for one call and will automatically reset to “On” when you hang up.

## Call Hold

When you are on an active call, you can place a call on hold and make a second call. The options “3way” and “Spkr” appear only when you are on an active call.

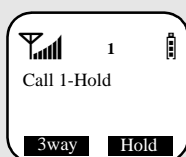
- 1 To place the active call on hold, press , then press  under “Hold”. You may then answer or place another call.





- 2 To toggle between the two calls, press , then press  under “Hold” again.

## Three-Way Calling

Using 3-way calling, you can combine two ongoing phone calls into one conversation. This option is available only when you initiate the second call. When you place or receive a phone call, a “3way” option appears in the bottom left-hand corner of the display screen.





To make a 3-way call:

1	Place or receive a phone call.
2	Press  under “3way” to place the first call on hold.
3	Enter the phone number for the second individual you want to call and press  .
4	After you reach the second individual, press  under “3way”. Both numbers will appear on your display.

## Call Forwarding

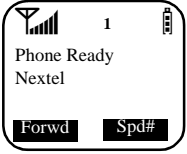

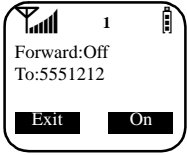

Call forwarding lets callers reach you wherever you are. Nextel’s Call Forwarding feature forwards calls to the number you designate. The instructions below tell you how to use Call Forwarding:

### Turning On Call Forward

1	Press  until you see “Forwd”.	
2	Press  under “Forwd”.	
3	Enter the phone number you want incoming calls forwarded to. (Or, you may press  to select a number from your stored list.)	
4	Press  under “On”.	
5	Press  under “Exit” after the <b>Please Wait</b> message displays.	

Your calls will now be forwarded to the number that you selected and you will see the Call Forward icon ( **1\*** or **2\*** ) with the forwarded line number on your screen. You can forward Line 1 or Line 2 independently.

### *Turning Off Call Forwarding*

1	Press  until you see "Forwd".
2	Press  under "Forwd".
3	Press  under "Off".
4	Press  under "Exit" after the <b>Please Wait</b> message displays.

### **Transferring Calls to Voice Mail**

Press  under "End" while your phone is ringing to transfer incoming calls directly to voice mail (purchase required).

### **Caller ID**

If you subscribe to Caller ID, your *i2000* phone automatically displays the phone number and/or name of the person calling (unless blocked by the caller), enabling you to decide whether to take the call or forward it to voice mail (purchase required).

**NOTE: Caller ID is not available in all areas.**

### *Displaying the Caller's Name*

A caller's phone number will display--if the caller's phone does not have Caller ID block. A caller's name will be displayed on your Nextel phone only if you previously programmed it in your phone list with one or more of the following:

- the caller's 10-digit Nextel phone number (703-555-9999)
- the caller's 11-digit regular number (1-703-555-9999).
- the caller's international number (+1-703-555-9999). *For more information, see "Creating, Editing and Using Stored Lists" on page 26.*

### *Maintaining Your Privacy with Per-Call and Per-Line Blocking*

Nextel provides two no-charge methods to prevent those you call from seeing your number on their own Caller ID displays.

Your Nextel phone number cannot be blocked from calls made to 911, 800, 877, 888, or 900 phone numbers.

Block Setting	What This Setting Does	To Set
<b>Per-Call Blocking</b>	Selectively blocks delivery of your phone number to other Caller ID units.	Press <b>*67</b> before dialing the call.
<b>Per-Line Blocking</b>	<p>Permanently blocks delivery of your phone number on every call you make.</p> <p>You can disable this feature on a per-call basis by pressing <b>*82</b> before the call.</p>	<p>You must order this feature from Nextel. You can disable this feature on a per-call basis by dialing <b>*82</b> before the call. To get your company's line automatically blocked on every call, contact Nextel Customer Care at 1-800-639-6111.</p>

### Alternate Line Service (not available on GSM)

The i2000 phone also allows you to have an alternate line. You can designate your alternate line as a "priority line" or you can use it to separate business and personal calls. If you are an alternate line customer, you will be given a unique phone number for each line.

- 1 If your Nextel phone is activated with two lines, you have the following options:
  - Different pricing by line
  - Distinct billing records to track usage
  - Separate address billing for an alternate line, for example, home billing
- 2 The following settings are independent for each phone line. When you enable a setting, it applies only to the active line.
  - Ringer Volume
  - Selectable Ring Styles
  - Call Forwarding
  - One-minute Beep
  - Automatic Display Timer
  - Resettable Timer
  - Total Call Timer

3 The alternate line does not have all the features of the first line:

- Line 2 shares the voice mailbox with Line 1; there is only one monthly charge.
- You cannot forward Line 2 to Line 1 and have the phone ring; the call defaults to Voice Mail.
- Text and Numeric Paging is not offered on Line 2.
- A call from line 2 will appear on the recipient's Caller ID as the Line 1 phone number.

### Selecting the Alternate Line

At the **Phone Ready** screen:

<p>1 Press <b>MENU</b> until you see “Line2”. (If you are on Line 2, you will see “Line1”.)</p>	 <p>The image shows a mobile phone screen with the text "Phone Ready Nextel" and "Line2" highlighted in a black box at the bottom. There are signal strength, battery, and line indicators at the top.</p>
<p>2 Do one of the following:</p> <ul style="list-style-type: none"> <li>• Press <b>1</b> under “Line2” to activate Line 2 when Line 1 is the active line.</li> <li>• Or, press <b>2</b> under “Line1” to activate Line 1 when Line 2 is the active line.</li> </ul>	

### Receiving Calls on Your Alternate Line



You can receive calls on either line, regardless of the active line setting.

- If the call is on the same line as the currently active line, the active line icon simply flashes.
- If the call is on the line that is not currently active, the active line icon remains lit and the additional line icon flashes.

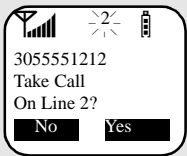
If you are on a call on one line:

<p>1 Press <b>1</b> under “Yes” to answer the call on the other line. Your original call will be placed on hold.</p>	 <p>The image shows a mobile phone screen with the text "3055551212", "Take Call", and "On Line 2?". At the bottom, there are two buttons: "No" and "Yes".</p>
--	---

**2** You can do one of the following to the active line:

- To end call, press . You will automatically revert to the original call. Or, to place the current call on hold, press  under “Hold”.
- To toggle between the two calls, press  under “Hold” again.

When both calls end, the phone remains active in the last line selected.

## Text and Numeric Paging

Your new Nextel Phone offers Text and Numeric Paging allowing callers to send you a page directly to your phone. Nextel Paging helps keep you in touch with co-workers and customers, regardless of where you travel on the Nextel National Network or the Nextel Worldwide Service. Whether it's your office calling with a last minute schedule change, or a customer trying to reach you with an important question, you'll be able to retrieve and respond to pages immediately, all from your Nextel Phone.

### About This Section

This section includes:

Text and Numeric Paging Features	Page 62
Notification of New Pages	Page 63
Accessing New Pages	Page 63
Sending a Page	Page 64

### Text and Numeric Paging Features

With Nextel Text and Numeric Paging, Nextel will:

- Allow numeric pages up to 20 characters in length and text pages up to 140 character messages.
- Accept your pages even if you are unavailable, if your phone is turned off, or if you are busy on another call.
- Alert you of a new text or numeric page, even if you are on another call.
- Store a page if you are using Nextel Direct Connect and deliver it upon completion of the call.
- Store the page if you are outside of the coverage area and deliver it as soon as you are back in a coverage area.
- Attempt continuous delivery of pages until successful, for up to 7 days.

With Nextel Text and Numeric Paging, your Nextel Phone will:

- Refer to text and numeric pages as Message Mail.
- Stamp the page with the time and date the page was left.
- Store up to 16 pages, at a time, that will remain until you delete them.
- Allow for "Auto Call Back" of a phone number that is included within a page, by pressing . If the page contains two phone numbers, Auto Call Back will dial the last number.

**NOTE: "Mail Waiting, Memory Full" displays when 16 message registers are full. (Messages must be erased before you can receive others.)**

## Notification of New Pages





When a new page arrives:

- “New Mail Read?” displays.
-  flashes at the top of the screen.
- Phone rings every 30 seconds as an alert/reminder.



## Accessing New Pages

When you receive a page, you can view it immediately or later:









### View a Page Immediately

- |   |  |
|---|--|
| 1 | Press  under “Now”. The number of new and saved pages is displayed briefly, followed by your first page.  |
| 2 | Press  under “Read”.  |
| 3 | Use the   on the side of the phone to scroll through messages. |

### Viewing a Page Later

Press  under “Later”. The  icon will stop flashing but the  icon will remain on the display to remind you that you have a page.

### Viewing Stored Pages

- |   |  |
|---|--|
| 1 | While in <b>Phone Ready</b> mode (see “Modes and Menus” on page 23) press  under “Mail”.  |
| 2 | If <b>Mesg Mail</b> isn’t highlighted already, press  to select it.   |
| 3 | Press  under “Ok”.  |
| 4 | Press  under “Read”.  |
| 5 | Use the   on the side of the phone to scroll through messages.                           |
| 6 | Press  under “Save” to Save the message. Or, press  under “Erase” to delete the message. |
| 7 | Press  under “Exit” to exit <b>Mesg Mail</b> .  |

## Auto Call Back

By simply pressing  while viewing a page, your Nextel Phone automatically dials the number that appears on your screen, even if the number is included in the middle of a text page. This allows you to respond immediately to important pages without having to remember the caller's number or fumble around for a pen and paper to write it down.

**NOTE: If the page you received contains two numbers, Auto Call Back will dial the last number.**

## Sending a Page

Nextel's Paging feature includes four options: Web Paging, Email Paging, Numeric Paging and Operator Assisted Paging. To use these features review the information below:

### Web Paging

Nextel's Web Paging enables you to page yourself, someone else or a group of Nextel customers and includes Schedule a Page, which allows you to send yourself reminders. To use Web Paging, follow the steps below:

- |          |   |
|----------|---|
| <b>1</b> | From your computer's Internet browser, go to <a href="http://www.nextel.com">www.nextel.com</a> and click "Send a Page".  |
| <b>2</b> | The browser automatically opens to "Send an Individual Page". To page an individual, or yourself, type the applicable 10-digit Nextel phone number (for example, 7035551234) in the "To" field.<br><br>To send a Group Page, select "Group Paging" under Options on the left side of the browser page. In the "To" field, type an individual's 10-digit Nextel phone number. Next, click the "Add" button. The information is inserted in a new window and the "To" field is cleared so you can enter another 10-digit Nextel phone number. You can send a Group Page to up to 20 Nextel users at one time. |
| <b>3</b> | To schedule a page for future delivery (up to 6 months in advance), click on "Schedule a Page". A new page appears with the following fields: Month, Day, Year, Hour, Min. (Minutes) and AM/PM. Click the down arrows at the end of each field to select the desired month, day, etc. Then click on the "OK" button to store your selections. (The "Cancel" button closes the page without saving your selections.)   |
| <b>4</b> | Type a Subject and a message in the message box.<br><br>You can click on the "Count Characters" button to have the system tell you the number of characters in your message. The total includes characters from the "To", "From", and "Subject" fields as well as system generated characters. You can send text pages up to 280 characters in length, sent as two sequential 140 character messages.   |

- |   |   |
|---|---|
| 5 | Click "Send Page" to send the message. (The "Clear" button removes the information from every field.)   |
| 6 | A new browser page opens with a copy of your message, the recipient's telephone number and a Claim Number. You can write down the Claim Number to check on the delivery status later. |

### Checking Delivery Status

To find out whether or not a message was delivered, and, if so when, follow the steps below:

- |   |  |
|---|--|
| 1 | Visit Nextel's home page at <a href="http://www.nextel.com">www.nextel.com</a> .         |
| 2 | Select "Send a Page".  |
| 3 | Select "Message Status" under Options (located on the left side of the browser page).    |
| 4 | Enter the Recipient Telephone Number and the Claim Number.                               |
| 5 | Click on the "Message Status" button. The system will display the requested information. |

### E-Mail Paging

From any email account, type the 10-digit phone number, of a Nextel customer, in the "To" field and add [@page.nextel.com](mailto:@page.nextel.com) (for example, [7035551234@page.nextel.com](mailto:7035551234@page.nextel.com)). The entire message can be up to 140 characters.

### Numeric Paging

- The caller must press "1" during your voice mail greeting.
- Only numeric pages can be sent.

### Operator Assisted Paging\*

- The caller can press "2" during your voice mail greeting. Or, call 1-800-NEXGRAM (1-800-639-4726).
- A text page can be sent immediately or for future delivery.
- The operator will send the page.

\* *The Operator Assisted Paging feature is required. There is also an additional charge for each message sent. For more information you can visit Nextel at [www.nextel.com](http://www.nextel.com) or call 1-800-639-6111 or dial 611 from your Nextel phone.*

# Nextel Worldwide<sup>SM</sup> Service

The Nextel Worldwide<sup>SM</sup> Service and the i2000 phone team-up to make keeping in touch easier than ever when you travel internationally. With your i2000 phone you can call clients, partners and co-workers, check voice mail, and more whether you're closing a major deal in Europe or negotiating a new contract in Canada.

## About This Section

This section includes:

Setting the Way Your Phone Searches for Networks	Page 66
Manually Searching for a Network	Page 67
Creating Your Phone's Network Priority List	Page 68

**NOTE: If you are unsure of the network you will be serviced by, please call Nextel International Roaming Customer Care toll free at 1(201) 531-5202 or see [www.nextel.com](http://www.nextel.com).**

## Setting the Way Your Phone Searches for Networks

You may want to configure the phone to search for a specific network or enable it to select the best network. The i2000 phone enables you to select the option that's right for you. And, you have six options to choose from:









- **Last Active**—This is the phone's default setting. It enables the phone to switch between iDEN and GSM systems that do not overlap (for example, if you send/receive calls on an iDEN network while in New York. Then you travel to Paris. Your phone will first search for an iDEN network. If it cannot locate one, it will automatically search for a GSM network).

**NOTE: This is the recommended setting, which reduces network registration time.**

- **Roam**—This option is useful when you are in an overlapping system-coverage area and have no preference for either the iDEN or the GSM network. Your i2000 phone will switch between iDEN and GSM until it finds an acceptable network.
- **iDEN Preferred**—This option is useful if your home system is iDEN and you travel to a country or region where GSM coverage is also available. Your i2000 phone always searches first for iDEN networks. If an iDEN network is not found, your phone will then search for a GSM network.
- **iDEN Only**—This option is useful when you are in an area that is covered by iDEN and GSM networks, but you want to use iDEN. Your i2000 phone attempts to register only on iDEN networks.
- **GSM Preferred**—This option is useful if your home system is GSM and you travel to a country or region where iDEN is also available. Your phone will always search for GSM networks first. If a GSM network is not found, your phone will then search for an iDEN network.

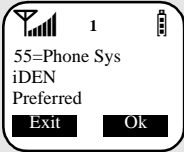
- **GSM Only**—This option is useful when you are in an area that is covered by iDEN and GSM, but you want to use GSM. Your *i2000* phone attempts to register only on GSM networks.

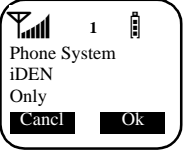

**NOTE: Nextel and other networks in North and Latin America are generally supported by iDEN. Networks in other areas of the world are generally GSM networks. Be aware that some features that are supported by iDEN networks are not supported when you connect to a GSM network.**

1 Press  until you see the “Prgm” menu option.	
2 Press  under “Prgm”.	
3 Press  then  . Press  under “Ok”.	
4 Press  until you see the desired option.	
5 Press  under “Ok”.	
6 Press  under “Exit” when finished.	

### Manually Searching for a Network

While you are on a GSM network, you can perform an automatic or manual search for available networks. A manual search allows you to view the available networks and make a selection rather than use the network automatically selected by the Nextel Worldwide Service.



1 Press  until you see the “Prgm” menu selection.	
2 Press  under “Prgm”.	

3 Press **5 jkl** then **7pqrs**.

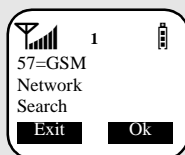

4 Press **•** under “Ok”.

5 At the **57=GSM Network Search** screen, do one of the following:

- Press **•** under “Ok”.
- Or, press **◀▶**. At “Manual Search”, press **•** under “Ok”. Then press **◀▶** to scroll through the network choices. *The network choices appear in the following order: Home, Preferred, Available.*

## Creating Your Phone’s Network Priority List

While you are on a GSM network, you can add, edit, or erase your preferred list of networks.

1 Press **MENU** until you see the “Prgm” menu selection.

2 Press **•** under “Prgm”.

3 Press **5 jkl** then **8 tuv**. Press **•** under “Ok”.

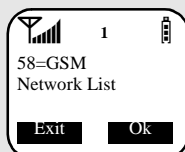

4 The **Add New Entry?** screen displays. (If you have not added any entries, the **Network List Empty** screen displays before the **Add New Entry?** screen.)

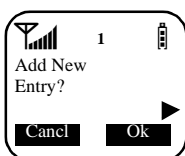

5 At the **Add New Entry?** screen, press **•** under “Ok”. This selection opens a network screen.

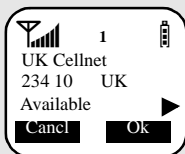

- 6 To add the network being displayed, press **OK** under “Ok”. Or, Press **Left Arrow** to view other available or known networks. At the desired network screen, press **OK** under “Ok”.

**NOTE: You can assign numbers 1 through 8 to your preferred network names. However, if you assign a new network name to a number that already has a stored network name, you will erase the stored name.**

- 7 At the preferred network screen, for example, UK Cellnet Pref#=\_ , assign a number, 1 through 8, to the network name.

The number that you assign provides the priority in which the phone looks for the systems when it is scanning the preferred list of networks.

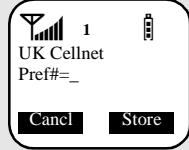

- 8 Press **OK** under “Store”.

- 9 Repeat steps 5, 6 and 7 to add additional networks. Or, exit this feature press **OK** under “Cancel”.

- 10 Press **OK** under “Exit” to return to **Phone Ready**.

### Editing Your Phone's Network Priority List

The previous section enabled you to assign a number to a network to indicate the order in which you wanted the phone to scan for a preferred network when establishing a connection. In this section you will learn how to reassign a number to a different network.

- 1 Press **MENU** until you see the “Prgm” menu selection.

- 2 Press **OK** under “Prgm”.

- 3 Press **5JKL** then **8TUV**. Press **OK** under “Ok”.



- 4 The **Add New Entry?** screen displays. Press **Left Arrow** until you see the **Edit Entry?** screen.

- 5 Press **OK** under “Ok”.

- 6 Press **Left Arrow** to scroll through your list of network.

- 7 Press **OK** under “Ok” when the screen displays the network you want to edit.
- 8 The phone displays the list of available networks. Press **Left Arrow** until the network you want to select displays.
- 9 Press **OK** under “Ok”. The phone displays the priority number and the newly assigned network.
- 10 Repeat steps 4 through 9 to edit additional entries.
- 11 Press **OK** under “Cancel” at the **Edit Entry?** screen,
- 12 Press **OK** under “Exit” at the **GSM Network List** screen to return to **Phone Ready**.

### *Erasing An Entry From Your Phone’s Network Priority List*

- 1 Press **MENU** until you see the “Prgm” menu selection.
- 2 Press **OK** under “Prgm”.
- 3 Press **5 jkl** then **8 tuv**. Press **OK** under “Ok”.
 

- 4 The **Add New Entry?** screen displays. Press **Left Arrow** until you see the **Erase Entry?** screen.
- 5 Press **OK** under “Ok”.
- 6 Press **Left Arrow** to view the network choices for each screen.
- 7 Press **OK** under “Ok” when the screen displays the network you want to erase.
- 8 Press **Left Arrow** to scroll through the list of available networks. Press **OK** under “Ok” when you view the network you want to erase from the list.
- 9 The **Erase?** screen appears again asking you to confirm your desire to erase the displayed network from the list.
- 10 Press **OK** under “Yes”. The network is removed from the list.

## Adding New Networks to Your Phone's Known Network List

While you are on a GSM network, you can add new network names and network codes to your known list.



- 1 Press **MENU** until you see the "Prgm" menu selection.
- 2 Press **OK** under "Prgm".
- 3 Press **5jkl** then **6mno**. The **56=GSM Network Name** screen displays.

- 4 Press **OK** under "Ok". The **Add New Entry?** screen displays.

**NOTE: Once you have added one new network name and network code to your known list, you also have the option to edit or erase these names and codes.**

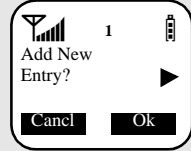

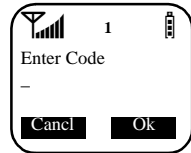

- 5 At the **Add New Entry?** screen, press **OK** under "Ok". The **Enter Code** screen appears.



- 6 Enter the five- or six-digit network code.
- 7 Press **OK** under "Store". The **Enter Name** screen then appears.
- 8 Enter the network name. Using your phone's keypad, press the key that has the character(s) you want to enter.

Each key, on your phone, has 3 to 4 letters. Whenever a key is pressed, the first character shown on that key will appear first. To change letters, quickly press the key until the desired letter appears. For example, the **3def** key contains the letters "d" "e" and "f". When this key is pressed, "d" will appear first. To enter an "e" you must press the **3def** key two times quickly. To enter an "f" you must press the **3def** key three times quickly.

**NOTE: If you make a mistake, press **←** to backspace and delete one or more character(s). Press **→** to move the cursor one or more space(s) forward.**

- 9 To add this network, press  under “Store”. (Selecting “Store” adds the displayed network to your phone’s known network list. You can now assign this network a priority number. See “*Creating Your Phone’s Network Priority List*” on page 68.)
- 10 Press  under “Cancel” at the **Edit Entry?** screen.
- 11 Press  under “Exit” at the **GSM Network Name** screen to return to **Phone Ready**.

---

# Private/Group Mode

## Nextel Direct Connect®

Nextel Direct Connect is a revolutionary way to communicate with your co-workers and clients...for a fraction of the cost of traditional cellular calls.

You may want to talk to a co-worker right away, but you don't want to page that person or leave a lengthy message. With Nextel Direct Connect's Private Call feature, you can find them wherever they are in your home coverage area.

Or, maybe you need to communicate a last-minute schedule change to your sales people... all 100 of them. It's easy with Nextel Direct Connect's Group Call. This digital two-way radio feature lets you contact all of them at once!





In addition, Nextel has created Nextel Business Networks<sup>SM</sup>, which allows you to communicate with individuals outside as well as inside your company. These Networks link Nextel customers in similar industries or geographic regions. So, if you need to reach a client, vendor, or contractor instantly, work smarter by joining the Nextel Business Networks. For more information, call 1-888-NEXTEL2 (1-888-639-8352).

**NOTE: Nextel Direct Connect® will only work in your home market area.**

This section includes everything you will need to know to take advantage of Nextel Direct Connect (two-way radio) service:

Using the Private/Group Speaker	Page 74
Placing Private Calls	Page 74
Receiving Private Calls	Page 75
Quickstore of Private IDs	Page 75
Sending a Call Alert	Page 76
Receiving/Responding to a Call Alert	Page 76
Call Alert Queuing	Page 77
Group Calls	Page 77
Group-Silent Programming	Page 79

## Displaying Your Private ID

- |   |  |
|---|--|
| 1 | Press  until you see the “Prgm” menu selection.   |
| 2 | Press  under “Prgm” and press  . |
| 3 | Press  under “Exit”.  |



## Using the Private/Group Speaker

You can enable or disable the speaker on your *i2000* phone for Direct Connect use. When the speaker is on, the caller’s voice can be heard over the speaker. When the speaker is off, the caller’s voice can only be heard through the earpiece of your phone.

### Turning the Speaker On

- |   |
|---|
| Press  . |
|---|

### Turning the Speaker Off

- |   |
|---|
| Press  .  will appear on your display. A brief alert tone will notify you of incoming Private or Group calls. |
|---|





## Placing Private Calls

From **Private** Mode, there are also two ways to reach an individual using Direct Connect. You can enter the person’s Private ID number then press the Push-To-Talk button. Or, you can store the person’s name and private ID number, then recall the number from a stored list. Whether you dial the person’s private ID directly or store it in a list--you must have the individual’s private ID to use Direct Connect. To learn how to store names and numbers, see “*Storing Names and Numbers*” on page 26 if you haven’t done so already.

### Entering the Private ID

- |   |   |
|---|---|
| 1 | Press  until you see <b>Prvt Ready</b> .     |
| 2 | Enter the Private ID.   |
| 3 | Press and hold the Push-To-Talk button on the side of the phone to talk. Both phones will chirp before your voice can be heard. |
| 4 | Release the Push-To-Talk button to listen.  |

## Selecting a Name from a Stored List

1	Press  until you see <b>Prvt Ready</b> .
2	Press  to scroll through the names. Or, Press  until “Name” appears. Press  under “Name” and enter the first initial of the name then press  to scroll through the names.
3	Press and hold the Push-To-Talk button on the side of the phone. The person’s phone will chirp to alert them that someone is calling.
4	Release the Push-To-Talk button to listen.

**NOTE:** You may receive certain display messages when making a Direct Connect call. See “Understanding Status Messages” on page 98.



## Receiving Private Calls

When you receive a Direct Connect call, your phone will switch to **Prvt Ready**. You will hear a chirp indicating that someone is calling you. Press and hold the Push-To-Talk button to talk and release it to listen.

## Quickstore of Private IDs



Quickstore allows you to quickly store a received or sent Private ID without having to enter the Programming menu.

With the Private ID displayed:

1	Press  under “Store”.
2	Enter the name associated with the Private ID.
3	Press  under “Store”. The “Stored” message displays with the name that you entered.

## Sending a Call Alert

You can send a Call Alert, which lets the recipient know that you would like to talk with them. When you send an alert, the recipient's phone will chirp several times and your name will appear on their display, if they have stored your Private ID.

1	Press  until you see <b>Prvt Ready</b> .
2	Press  under "Alert".
3	Select the person you want to alert by entering their Private ID or selecting their name from a stored list. (See "Selecting a Name from a Stored List" on page 75.)
4	Press and hold the Push-To-Talk button until " <b>Alert-Sent Successful</b> " displays. The alert plays intermittently until the individual clears it.

## Receiving/Responding to a Call Alert

When you receive an alert, your phone will automatically change to **Prvt Ready** mode. It will also chirp and you will see the name or the number (if you have not stored the individual in a list) of the caller.

1	Press and hold the Push-To-Talk button to answer the Call Alert.
2	Press  under "Clear", or any key, to clear the Call Alert.

**NOTE:** Call Alert allows you to contact another Nextel Direct Connect subscriber at no cost and avoid airtime charges.

**NOTE:** Until you answer or clear the Call Alert, you will not receive any additional Phone, Private, or Group calls.



## Call Alert Queuing

Call Alert Queuing is a feature that allows you to save up to eight Call Alerts in a Queue or list.

### Placing/Clearing a Call Alert in the Queue

When you receive a Call Alert, you can either clear the Call Alert or save it to the list for later recall.



To clear a Call Alert, press  under "Clear".

To place a Call Alert in the Queue, press  under "Queue" or .

**NOTE: If you receive multiple Call Alerts, the last received Call Alert displays and the remaining Call Alerts are stacked at the beginning of the queue.**

### Responding to a Call Alert within the Queue

You can respond to the Call Alerts in any order. To select a Call Alert for response:









- 1 Press  under "Queue".
- 2 Press  to scroll to the desired Call Alert.
- 3 Press and hold the Push-To-Talk button to answer the Call Alert. After you respond to the Alert, it is removed from the queue.

## Group Calls



In a Group call, you can communicate instantly with a group of people (up to 100) that you have previously set up as a "Talkgroup". Your Sales Representative or Nextel Customer Care must set up your Talkgroup by providing you with a Talkgroup number for each Talkgroup. After you have the number, you can assign each Talkgroup number a name and store it in your i2000 phone (see "Naming a Talkgroup" on page 78).

Talkgroups appear on your display as numbers or programmed names such as SALES TEAM or Talkgrp 5. Your Nextel Phone can store up to 30 Talkgroups. You can receive Group calls only in the Talkgroups that you have predefined. Any communication activity within a Talkgroup automatically switches your phone to **Group** mode.

### Naming a Talkgroup

1	Press  until you see the “Prgm” menu selection.
2	Press  under “Prgm”.
1	Press  then  .
2	Press  under “Ok”.
3	At <b>Add New Entry?</b> , press  under “Ok”.
4	At <b>Enter ID</b> , enter the desired Talkgroup number.
5	Press  under “Store”.
6	At <b>Enter Name</b> , enter the desired Talkgroup name.
7	Press  under “Store”.
8	When finished, press  under “Exit”.

### Making a Group Call

1	From <b>Group Mode</b> , press  to scroll to the desired Talkgroup.
2	Press  under “Ok”.
3	Press and hold the Push-To-Talk button to talk. Release the Push-To-Talk button to listen.

### Receiving a Group Call

When you receive a Group call, you will hear a chirp. Your Nextel phone automatically switches to **Group** mode and the Talkgroup name displays. To join a Group call:

1	Wait for the caller to finish speaking.
2	Press and hold the Push-To-Talk button to talk. Release the Push-To-Talk button to listen.







**NOTE:** You can receive Group Calls only in the Talkgroup that you have predefined.

---

## Group-Silent Programming

Group-Silent Programming enables you to silence incoming alerts and voices:

### Turning Group-Silent On/Off

1	Press  until you see the “Prgm” menu selection.
2	Press  under “Prgm”.
1	Press  then  .
2	Press  under “On” or “Off”. (The available option depends on the current setting being used. For example, if “On” is the current setting, “Off” will be an option.)
3	Press  under “Exit”. The <b>Group Ready</b> screen displays as <b>Group-Silent</b> .

# Customizing the i2000 Phone

## About This Section







You can customize the settings on your i2000 phone by changing the display language, setting the date and time, and by using the programming menus. Many of the menus have been discussed throughout this guide.

You may access the menus from the Phone, Private, or Group modes.

Changing the Display Language	Page 80
Setting the Time and Date Format	Page 81
Setting the Ringer Volume	Page 83
Selecting a Ring Style	Page 83
Setting VibraCall™	Page 84
Programming Menus	Page 86

## Changing the Display Language

You can customize your i2000 phone to display menus in English, Spanish, French, or Brazilian Portuguese. The default language is English. You can manually select one of these languages or have your i2000 phone select one for you (Automatic). To change the displayed language:

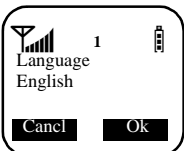
1	Press  until "Prgm" is shown.	
2	Press  under "Prgm" then press  , then  .	
3	Press  under "Ok".	
4	Press  to scroll through the language options. Selecting "Cancel" at any time retains the current language selection.	

- 5 When the desired language appears on your display, press  under “Ok”. The displayed text immediately changes to the selected language.

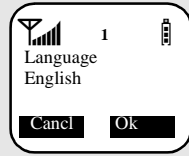

- 6 Press  under “Exit” to exit this menu.

## Setting the Time and Date Format

**IMPORTANT:** The Time and Date may not be available in your area and may not appear on your display. Once this feature becomes available, your i2000 phone will automatically display the local time and date.

**NOTE: The Time and Date will not appear on your display when operating on Nextel Worldwide Service.**

You have a choice of a 12- or a 24-hour clock format, as shown in the table below:

<b>12-Hour Display</b>	12:00 am	6:25 am	12:00 pm	10:25 pm
<b>24-Hour Display</b>	00:00	06:25	12:00	22:25

You have a choice of either a MM/DD (month/day) or a DD/MM (day/month) date format as shown in the table below.







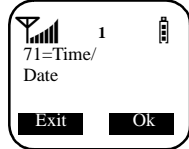

<b>Date</b>	<b>Month/Day Format (MM/DD)</b>	<b>Day/Month Format (DD/MM)</b>
January 2nd	01/02	02/01
December 31st	12/31	31/12

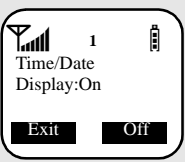
**NOTE: All of the modes (Phone Ready, Private Ready and Group Ready) display the time and date on the third line of the display. To set the time and date format once this feature is activated, follow these steps:**

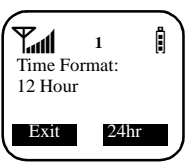
- 1 Press  until you see the “Prgm” menu option.

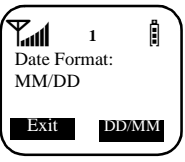





- 2 Press  under “Prgm” then press  then .



<p>3 Press  under “Ok”. The Time/Date screen displays. The default (preset) time and date format is set to “On”. However, the time and date does not display until the Nextel National Network activates this feature.</p>	
<p>4 Press  until you see the Time Format screen.</p>	
<p>5 Do one of the following:</p> <ul style="list-style-type: none"> <li>• To use the 12-hour format, go to the next step.</li> <li>• To use the 24-hour format, press  under “24hr”.</li> </ul>	
<p>6 Press  until you see the Date Format screen.</p>	
<p>7 Do one of the following:</p> <ul style="list-style-type: none"> <li>• To use the MM/DD format, press  under “Exit”.</li> <li>• To use the DD/MM format, press  under “DD/MM”.</li> </ul>	
<p>8 Press  under “Exit” twice. The <b>Phone</b>, <b>Private</b>, and <b>Group</b> screens now display the selected time and date formats.</p>	



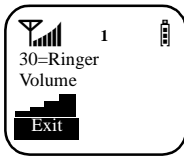







## Setting the Ringer Volume

You can adjust the ringer volume for incoming calls. For Alternate Line users, be sure to select the phone line before setting the ringer volume (See “Alternate Line Service (not available on GSM)” on page 59.)

1	Press  until you see the “Prgm” menu selection.	
2	Press  under “Prgm” then press  then  . The display shows your current ringer volume.	
3	Press  on the side of the phone to listen as you raise or lower the volume. The lowest setting is “Volume Silent”.	
4	Once the desired level is found, press  under “Exit”.	

## Selecting a Ring Style

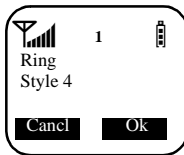

With your i2000 phone, you even have a choice on how you’d like to be notified of incoming calls. Your Nextel phone has nine selectable ring styles. Customers with Alternate Line service can use the same ring style or different ring styles for each phone line, so you can tell which line is ringing. Make sure you are on the correct line when selecting a ring style.

1	Press  until you see the “Prgm” menu selection.	
2	Press  under “Prgm” then press  then  . The display shows your current ring style.	
3	Press  under “Ok”.	
4	Press  to scroll through the available Ring Styles.	
5	Press  on the side of the phone to listen to the selected ring style.	
6	Once the desired ring is found, press  under “Ok”.	
7	Press  under “Exit”.	





## Setting VibraCall™

VibraCall is a vibration alert system that notifies you of incoming Phone, Private, or Group calls and messages by vibration. You can select this alert system for all incoming calls/messages, or select individual services for VibraCall.

**NOTE: When you set vibration alerts, they are set only for the current line. If you have a second phone line, you must select “Line 2” and repeat the procedure for selecting all services or selecting individual services to vibrate.**

VibraCall Settings	What this setting does
<b>Vibrate Alert</b>	Vibrates for all incoming calls and messages.  -- Vibrate All appears on the display.  -- Speaker Off appears on the display to remind you that the audio will be heard through the earpiece instead of the speaker.
<b>Phone Vibrate</b>	Vibrates only for incoming phone calls.
<b>Phone Vibrate/ Ring</b>	Vibrates and rings for incoming phone calls.
<b>Mail Vibe</b>	Vibrates for incoming mail messages.
<b>Group/Prvt Vibe</b>	Vibrates for incoming group and private calls.

## Using Vibrate Alert (for all incoming calls and messages)

- 1 Press  until you see the “Prgm” option.
- 2 Press  under “Prgm”, press  then  under “All”. The i2000 phone will emit a brief vibration and also on subsequent power-ups.













Or, use the following shortcut:





Press  once.

## Using Phone, Mail and Group/Prvt Vibrate Option

To use **Phone Vibrate**, **Phone Vibrate/Ring**, **Mail Vibe** or **Group/Prvt Vibe** follow the steps below:

- 1 Press  until you see the “Prgm” option.
- 2 Press  under “Prgm”, press .
- 3 Press  until you see the “Selct” option.
- 4 Press  under “Selct”. The first selection is **Phone Vibrate**. Then-press  to scroll to Mail Vibe, then Group/Prvt Vibe.
  - To use Phone Vibrate/Ring, from **Phone Vibrate** display, press  then press  under “V/Rng”.
- 5 Press  under “On” or “Off” (whichever is applicable).
- 6 Press  under “Exit”.

## Programming Menus

1	Press  until you see “Prgm” on the display.
2	Press  under “Prgm”.
3	Press  under “Ok”.
4	Press  to scroll to the desired programming menu option or enter the option keypad number.

## Programming Menus Shortcut and Options

Option Number	Menu Option	Function
1	<b>Own Ph #</b>	Automatically stores the telephone number of your Nextel phone after you receive the first incoming call. Or, you can enter the number. Also, view your number. See “ <i>Programming Your Own Phone Number</i> ” on page 31.
2	<b>Own Pvt ID</b>	Displays the private ID number of your phone. See “ <i>Displaying Your Private ID</i> ” on page 74.
3	<b>Mail Display: On/Off</b>	Turns on and off the <b>New Mail</b> message that is displayed with incoming Voice or Message.
4	<b>Manual Lock: On/Off</b>	Locks your phone to prevent unauthorized use. You must enter a password to unlock it.  Even with the manual lock on, you can reach emergency help by pressing and holding the  key.
5	<b>Auto Lock: On/Off</b>	Automatically locks your phone each time it is powered off to prevent unauthorized use.
6	<b>Auto Answer: On/Off</b>	Turns on or off automatic answering of incoming phone calls after 1-4 rings.

Option Number	Menu Option	Function
9	<b>Vibrate Alert: On/Off</b>	Provides non-audible notification of incoming phone calls and messages. See <i>“Last 10 Numbers Received/Sent Call List”</i> on page 37.
10	<b>Last Call Timer</b>	Displays the duration of the most recent phone call.
11	<b>Display Timer: On/Off</b>	Turns on or off automatic display of the Last Call Timer at the end of each phone call.
12	<b>Reset Timer</b>	Displays cumulative airtime of all phone calls since the last time the timer was reset.
13	<b>Total Timer</b>	Displays cumulative airtime of all phone calls.
14	<b>1 Minute Beep: On/Off</b>	Automatically signals each minute of elapsed phone airtime with an audible beep.
20	<b>Phone/Prvt List</b>	Adds phone and private numbers in one procedure. See <i>“Creating, Editing and Using Stored Lists”</i> on page 26.
21	<b>Phone List Edit</b>	Edits or erases up to 100 frequently called phone numbers and associated names. See <i>“Edit a Phone Number or Associated Name or Speed Dial Number”</i> on page 29.
22	<b>Prvt ID List Edit</b>	Edits or erases up to 100 Private numbers and associated names. See <i>“Editing a Private ID or Associated Name”</i> on page 29.
23	<b>Talkgrp List Program</b>	Adds, edits, or erases numbers and associated names for up to 10 pre-programmed talkgroups. See <i>“Naming a Talkgroup”</i> on page 78.
24	<b>Area List Program</b>	Adds, edits, or erases numbers and associated names for up to 50 targeted areas.
30	<b>Ringer Volume</b>	Sets the ringer volume using the volume control keys, or lower the volume to silence the ringer.

Option Number	Menu Option	Function
31	<b>Set Ring Style</b>	Selects a distinct ring style for incoming phone calls.
32	<b>Mail Volume</b>	Sets the volume of incoming pages and Voice Mail using the volume control keys. Or lower the volume to silence the mail alert tones.
33	<b>Earpiece Volume</b>	Set the default earpiece volume using the volume control keys.
34	<b>Keypad Volume</b>	Sets the volume of the keypad tones using the volume control keys, or to silence the keypad tones.
35	<b>Speaker Volume</b>	Temporarily adjusts the Private/Group speaker or Speakerphone volume for noisy environments.
36	<b>Spkr Vol Set Tone</b>	Turns the speaker volume set tones on or off.
38	<b>Silent Group</b>	Silences all incoming Group Call alerts and voice activity. When set, your screen displays the message, "Group-Silent". See "Group-Silent Programming" on page 79.
40	<b>Change Passcode</b>	Changes your secret four-digit password from the initial setting 0000.
46	<b>Change SIM PIN</b>	Changes your personal SIM card PIN from the initial setting of "0000".
47	<b>Require SIM PIN</b>	Sets or removes PIN requirement when you turn on your i2000 phone.
55	<b>Phone Sys</b>	Sets your i2000 phone for travel by choosing a phone system setting.
56	<b>GSM Network Name</b>	Adds, edits, or erases network names and network codes to the known list. ( <i>GSM use only</i> )
57	<b>GSM Network Search</b>	Automatically or manually searches for an available network. ( <i>GSM use only</i> )
58	<b>GSM Network List</b>	Adds, edits, or erases entries in your preferred list. View entries from the known list. ( <i>GSM use only</i> )

Option Number	Menu Option	Function
70	Language	Selects one of four languages for your display text. <i>The default is English.</i> See “ <i>Changing the Display Language</i> ” on page 80.
71	Time/Date	Selects the standard or military time and MM/DD or DD/MM date format.

	<p>Do not attempt to use program menus 41, 42, 43, 51 and 60 because you can permanently damage your phone. They are for Nextel Customer Care use only and should never be programmed by customers unless directed to do so by technical support.</p>
---	---

Option Number	Menu Option	Function
41	Feature Reset	Returns all feature settings to their original defaults.
42	Master Clear	Performs Feature Reset and erases all stored lists.
43	Master Reset*	<p>Resets the phone’s identification number.</p> <p>* <i>This feature does not display while connected to GSM networks.</i></p> <p style="text-align: center;">  <b>And, it must never be used outside of the U.S.</b> </p>
51	Net ID	Edits the pre-programmed Network number list and select roaming options.
60	Set Baud Rate	<p>This option should not be used. It is recommended that you leave it at the default setting.</p> <p><b>NOTE: This option is only available with the data feature and is not used with this phone.</b></p>

## Ordering Information

*Nextel Business Networks allow you to communicate with individuals outside as well as inside your company. These Networks link Nextel customers in similar industries or geographies. So, if you need to reach a client, vendor, or contractor instantly, work smarter by joining the Nextel Business Networks. Call 1-888-NEXTEL2 (1-888-639-8352).*

*Various accessories are available for use with your i2000 phone, including a Hands-Free Car Kit, Swivel Belt Clip, Cigarette Lighter Adaptor and International power adaptors. To order accessories discussed in this guide, or for a brochure of additional accessories, call **Nextel Next-day Accessories at 1-800-914-3240** or contact your Nextel Authorized Representative.*

*Call **Nextel Customer Care at 1-800-639-6111 or 611 from your i2000** to order any services discussed in this guide, including Direct Connect, Additional Phone Services, Voice Mail, Paging Features and much more!*

*For Information on **Direct Protect<sup>SM</sup> insurance** protection for your Nextel phone and more, call **1-888-352-9182** or contact your Nextel Authorized Representative.*

*Visit us at [www.nextel.com](http://www.nextel.com) to learn more about Nextel products and services!*

---

# Accessories

## About This Section

This section includes the following topics:

Leather Carry Case	Page 91
Batteries	Page 91
Travel Charger	Page 92
Cigarette Lighter Adaptor	Page 93
Desktop Dual-Pocket Charger	Page 95
Audio Adaptor	Page 96
Dash Mount Holder	Page 97

## Leather Carry Case

The leather carry case with belt clip allows for easy attachment to a belt or purse. This case accommodates i2000 phone travel chargers, audio accessories, car accessories, and all battery types.

## Batteries

**NOTE: For best results, charge the batteries within the temperature range of 10°C to 40°C (50°F to 104°).**

**NOTE: Prolonged charging is not recommended. For battery charging guidelines, see Table below.**

### *Charging Lithium Ion Batteries*

Table provides the approximate time to fully charge a battery using a Motorola iDEN Approved Lithium Ion battery charger.

**Table 1: Battery Charging Times**

MOTOROLA BATTERIES		
Kit Number	Description/Chemistry	Charging Time <sup>a</sup>
NTN1645	Slim Lithium Ion	2.5 Hours
NTN1644	Standard Lithium Ion	3 Hours

a. Charging times are based on a fully discharged battery.

For optimal battery life, use a Motorola iDEN Approved Lithium Ion battery charger with your Motorola iDEN Lithium Ion battery. Other chargers may not fully charge your Lithium Ion battery or may yield a reduced number of cycles.

### ***Battery Operating Instructions***

- Extreme temperatures will degrade battery performance. Do not store your battery where temperatures exceed 60°C (140°F) or fall below -20°C (4°F).
- This Lithium Ion battery has a self discharge rate and without use, will lose about 1% of its charge per day.
- The battery capacity will be degraded if stored for long periods while fully charged. If long term storage is required, store at half capacity.
- The Motorola iDEN Approved Lithium Ion chargers will provide optimum performance. Other chargers may not fully charge your iDEN Lithium Ion battery or may yield reduced number of charge cycles.
- If the battery appears inoperative, the internal protection circuitry may have been activated. Remove the battery from the phone and put it into the charger for several minutes to reset the circuitry.
- When batteries are not in use, always store them in the plastic safety tray.

### **Travel Charger**

Using the NPN6197 Travel Charger, you can charge a battery from an AC outlet. On one end of the Travel Charger, an accessory connector attaches to the bottom of the phone unit. At the other (AC outlet) end of the device, there is a compact housing that contains the plug-in power supply. A lightweight cable connects the two ends (accessory connector and supply).

A power light (green LED) on the accessory power supply indicates that the Travel Charger is plugged in.

Additional adaptor plugs to accommodate various European power outlets can be purchased separately.

## Using the Travel Charger

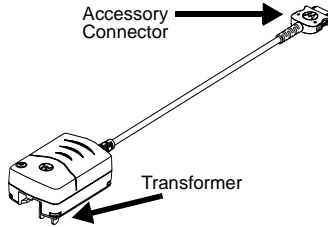

- 1 While holding the *i2000* phone with its front toward you, insert the accessory connector (with the Motorola logo facing you) into the slot on the bottom of the *i2000* phone until you hear a click.
- 2 Flip open the prongs, and plug the Travel Charger transformer into an AC wall outlet. The power light (green LED) on the accessory power supply will come on.

## Travel Charger Operating Specifications

Input voltage range: 90-264 VAC @ 50/60 Hz.

Operating temperature range: 0°C to +50°C

## Cigarette Lighter Adaptor

The NTN1628 Cigarette Lighter Adaptor provides power to the phone and charges the phone's Lithium Ion battery.

The power light (green LED) will light when the adaptor is receiving power.

### Using the Cigarette Lighter Adaptor

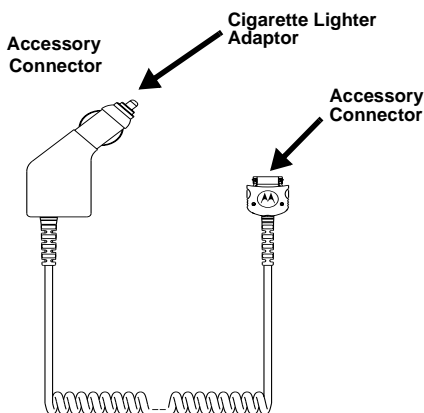

- 1 Attach the Cigarette Lighter Adaptor's accessory connector to the bottom of the *i2000* phone. While holding the *i2000* phone with its front toward you, insert the accessory connector (with the Motorola logo facing you) into the slot on the bottom of the *i2000* phone until you hear a click.
- 2 Remove the vehicle's cigarette lighter plug from the cigarette lighter receptacle.
- 3 Plug the cigarette lighter adaptor into the cigarette lighter receptacle. The power light (green LED) will come on.
- 4 The *i2000* phone may be turned off, turned on, or in use.

### Removing the Cigarette Lighter Adaptor

- 1 Unplug the adaptor's cigarette lighter adaptor from the vehicle's cigarette lighter receptacle.
- 2 Press the latches on the accessory connector.
- 3 Pull the accessory connector from the bottom of the *i2000* phone.

## Cigarette Lighter Adaptor Operating Specifications

Operating voltage range: 10.8 - 33.0 Vdc.

Operating temperature range: -30°C to +60°C

## Desktop Dual-Pocket Charger

The NTN1627 Desktop Dual-Pocket Charger charges Motorola authorized batteries, as listed on page 91, for the *i2000* phone.

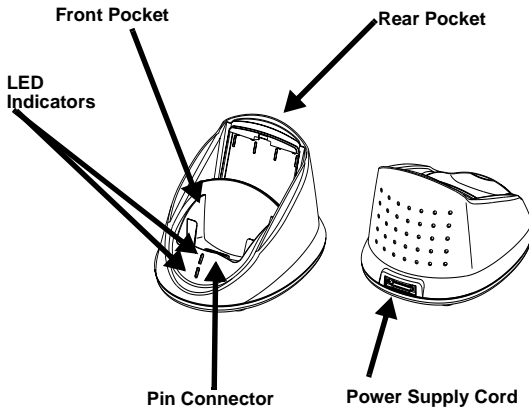

- 1 Plug the flat end of the power-supply cord, with the Ⓜ logo facing down, into the receptacle labeled "Charging" on the back of the charger.
- 2 Plug the transformer end of the power-supply cord into any standard AC wall outlet.
- 3 Insert an *i2000* phone with an attached battery, into the charger's front pocket. This is done by inserting the bottom of the *i2000* phone into the pin connector in the bottom of the charger's front pocket.
- 4 If the *i2000* phone is properly seated in the front pocket, the charger's front pocket LED indicator will light green to indicate that the battery is being charged. If a battery is in the rear pocket and the *i2000* phone with a battery is inserted into the front pocket, the battery in the front pocket will charge to full capacity before the battery in the rear pocket is charged. The LED for the rear pocket will flash yellow, indicating that its battery is waiting to be charged.
- 5 The charger has the capability of displaying the battery's charge status. The indicator will show the following: solid red=1-30%; solid yellow=31-60%; flashing green=61-90%; solid green=91-100%.

## Audio Adaptor

The Audio Adaptor connects an earpiece microphone to your *i2000* phone for privacy and hands-free operation.

The Audio Adaptor fits onto the bottom of the *i2000* phone and provides a standard 2.5mm jack connection for an earpiece microphone or headset. (The Audio Adaptor will be packaged with an audio accessory, such as an earpiece microphone or a headset.)

### *Using the Audio Adaptor*

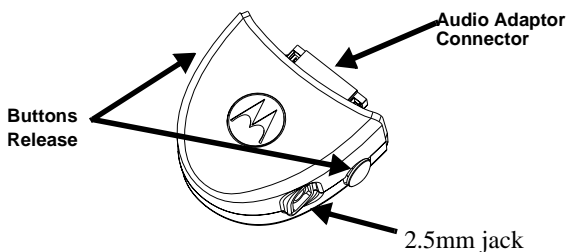

- 1 Hold the phone and the Audio Adaptor facing you so that you see the Motorola logo on the adaptor.
- 2 Insert the Audio Adaptor's connector into the *i2000* phone receptacle. You will hear the connector snap into place.

### *Attaching/Detaching the Earpiece Microphone*

- 1 Insert the 2.5mm plug of the earpiece microphone cord into the jack of the Audio Adaptor.
- 2 Pull on the plug, not the cord, to remove the earpiece microphone.

### *Removing the Audio Adaptor*

- 1 Press the buttons on the side of the Audio Adaptor.
- 2 Pull the Audio Adaptor from the *i2000* phone.

---

## Dash Mount Holder

The Dash Mount Holder provides a convenient holder for your i2000 phone. The Dash Mount Holder can be installed either horizontally or vertically.

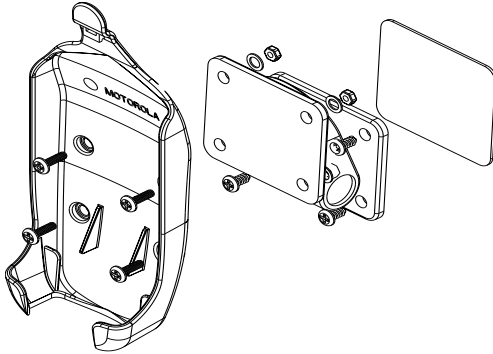

 <p>Caution</p>	<p><b>Do not place the dash mount holder over the air bag or in the air bag deployment area.</b></p>
--	--

### *Using the Dash Mount Holder*

- |   |
|---|
| <p><b>1</b> Mount the Dash Mount Holder to the dash of your vehicle by securing the four self-tapping screws to the base of the holder. Or, for a semi-permanent installation, use an adhesive strip.</p> |
| <p><b>2</b> Snap your phone securely into the holder.</p>   |

## Other Important Information

### About This Section

This section includes the following topics:

Nextel Customer Care	Page 98
Understanding Status Messages	Page 98
Nextel Terms and Conditions of Service	Page 100

### Nextel Customer Care

Relax! Nextel Customer Care is here to help. There are lots of features packed into your Nextel Worldwide Service...and into your i2000 phone. But don't worry. If, after reading this guide, you still have questions about coverage, billing, Nextel Direct Connect or any other service or feature, call us.

International Roaming Customer Care Support: 1(201) 531-5202 (toll free) or Domestic Customer Care: 1(800) 639-6111 or 611 from your Nextel phone.

We'll be happy to give you help, explanations and anything else you need to enjoy your Nextel Worldwide Service as soon as possible!

Before you call Nextel Customer Care for service or to resolve an issue, be sure to have your SIM ID number and your model number ready. The SIM ID can be found on the SIM card, and the model number is located on your Nextel phone behind the battery. You'll want to record these numbers, and keep them handy, so that you can replace the battery prior to making your call.

### Understanding Status Messages

You may receive status messages under certain conditions. Before contacting your carrier, note the message, numeric code, and the conditions under which it appeared. The following table lists and describes the status messages.

Status Messages	Message Description
<b>Number Not in Service</b>	The number that you entered is not valid.
<b>User Not Available</b>	The phone that you called is either busy, out-of-range, or turned off. Please try again later.
<b>User Not Authorized</b>	The party that you called has not purchased this service.
<b>Please Try Later</b>	This service is temporarily not available. Please try again later.

Status Messages	Message Description
<b>User Busy in Private</b>	The phone that you called is busy in a Private call.
<b>User Busy in Data</b>	The phone that you called is busy in a dial-up call.
<b>Service Restricted</b>	This service was restricted by your service provider, this service was not purchased, or the i2000 has detected the presence of a network that is not part of the Nextel Worldwide Service.
<b>Service Not Available</b>	This feature is not available on the current network.
<b>System Busy Try Later</b>	The system is experiencing heavy traffic. Please try again later.
<b>Service Conflict</b>	This service cannot be enabled because an incompatible service has already been turned on.
<b>Please Try Again</b>	An error occurred. Note the error code and try again.
<b>Self Check Error</b>	A fault was detected with your Nextel phone. If this error recurs, note the error code and contact Customer Care.
<b>Self Check Fail</b>	An operational fault was detected with your phone. Note the numeric code, turn your Nextel phone off, and contact Customer Care.
<b>PIN Blocked Call Your Provider</b>	The incorrect PIN was entered three consecutive times. You will be unable to send or receive call on your i2000. Call your service provider to have them obtain the PIN Unblocked Key (PUK) code.
<b>Insert SIM</b>	Your SIM Card is not being detected. Please check to ensure that you have inserted the SIM Card.
<b>Check SIM Card</b>	Please check your SIM Card to make sure it has been inserted properly.
<b>Wrong PIN</b>	You have entered an incorrect PIN number.
<b>Wrong Code</b>	Your phone will not accept a non-Nextel SIM card.

## Nextel Terms and Conditions of Service

### Terms and Conditions

**TERMS AND CONDITIONS OF SERVICE:** Before calling the Nextel Customer Service Activation Number contained in these materials, you ("Customer") must read and agree to the following terms and conditions of Nextel wireless telephone service ("Service"). By calling to activate service, Customer applies and subscribes for Services provided by Nextel (the "Company") and confirms that Customer has read, understands, agrees to and accepts the terms and conditions stated herein. Customer understands that Company will rely upon the information provided by Customer including credit information, in making a decision to provide Services. Customer understands that Company may request and verify Customer's bank references and perform a credit history check utilizing standard commercial credit reference services in connection with Company's review of the Customer's credit worthiness. Customer understands that a security deposit or air time usage limit may be required.

1. **USE OF SERVICE** — Customer must comply with all FCC rules and regulations. Customer will not use the Service for any unlawful purpose. Customer will not use the Service in aircraft.

2. **CREDIT APPLICATION** — This Agreement shall be contingent upon Company's approval of Customer's credit. Company may require Customer to update credit information from time to time. Customer warrants and represents that all credit information furnished is complete, accurate and true. If Company subsequently determines that any statements regarding Customer's credit are false, incomplete or inaccurate, Company may declare Customer to be in default and may exercise any remedies it has under these Terms and Conditions of Service and at law or in equity.

3. **CUSTOMER RADIO EQUIPMENT** — Company is not responsible for the installation, operation, quality of transmission or maintenance of the equipment. Company reserves the right to change or remove assigned codes and/or telephone numbers when such change is reasonably necessary in the conduct of its business. Customer does not have any proprietary interest in such codes or telephone numbers. Federal and state laws make it illegal for third parties to listen in on service, however complete privacy cannot be guaranteed.

4. **SECURITY DEPOSITS** — Company has the right, in its sole discretion, to require Customer to make a deposit to guarantee payment of Service charges. Customer grants Company a security interest in such deposits, to secure the payment of all sums due thereunder as well as the performance of all other obligations Customer may have to the Company whether now existing or hereafter arising. Upon termination of Service, Company may apply the deposit against any outstanding Service charges of Customer or any other amount owed to Company. Company reserves the right to interrupt services if service appears to have excessive charges or any unusual calling patterns are observed on Customer's account. Such interruption may be done to protect Customer or Company as the Company determines in its sole discretion.

5. **RATES, CHARGES AND PAYMENTS** — Company shall issue invoices for Service on a monthly basis which are due and payable upon receipt. Monthly Access Charges shall be invoiced in advance. Airtime and long-distance charges shall be invoiced in arrears. Customer is responsible to pay Company on a timely basis, for charges for Service payments as set forth on the Company's then-current rate plans, and any modifications thereto. Customer acknowledges that chargeable time for telephone calls originated by a unit begins when a connection is established with Company facilities. Customer accepts responsibility for Airtime charges from invoicing telephone calls to its mobile unit from the time that Customer responds to the call. If Customer disputes any Service charges, Customer must pay entire amount set forth in the invoice by the due date and submit a written explanation within forty-five (45) days from the date on the invoice. If Company determines that an error was made on Customer's invoice, Company shall credit Customer's account in the amount of the error. If Customer does not pay the amount in dispute, Company may exercise any remedies it may have for non-payment of Service

charges. Company reserves the right to modify any and all elements of the Service charges at any time. Payments which are not received within thirty (30) days from the day of the invoice shall be subject to late payment charges. If Customer does not make payments, such failure shall be a default and Company shall be entitled to exercise any remedies it may have under these Terms and Conditions of Service or at law or in equity.

**6. NONPAYMENT/BREACH** — A late payment charge of 1.5% (or the maximum interest rate permitted by law) per month, may be applied to Customer's account if monthly invoices are not paid by the due date. The later payment charge is applied to the total unpaid balance due and outstanding. The late payment charge is for costs related to the non-timely payment and shall be deemed an interest payment. A charge of \$25.00 will be made by Company for any check or negotiable instrument tendered by Customer and returned unpaid by a financial institution for any reason. Company may demand payment by money order, cashier's check or similarly secure form of payment, at Company's discretion. If Customer obtains the service of a collection or repossession agency or an attorney to assist the Company in remedying Customer's breach of any payment obligations, Customer shall be liable for this expense. Customer understands that in the event of nonpayment of charges or any other breach of these Terms and Conditions of Service in addition to any other remedies the Company may have, Company may temporarily or permanently terminate Service to Customer. If Company disconnects the Service, Customer shall be liable to pay a re-connect charge of \$25.00 per unit, in addition to the outstanding Service charges before the Company will reactivate Service. Company reserves the right to modify the terms of service as a precondition to reactivating service.

**7. TAXES** — Customer is responsible for all federal, state and local taxes for fees which are computed in accordance with the appropriate tax laws for Services.

**8. LIMITATION AND CONDITION OF LIABILITY/INDEMNITY** — The Company's sole liability for Service disruption, whether caused by the negligence of the Company or otherwise, is limited to a credit allowance not exceeding an amount equal to the proportionate charge to the Customer for the period of Service disruption. In no event is the company or lessor liable for actual consequential or special damages caused by its negligence or otherwise nor for economic loss, personal injuries or property damages sustained by customer or any third parties. Customer agrees to indemnify, defend and hold Company harmless from any Customer violations of FCC rules and regulations or Customer violation of any statutes, ordinances or laws of any local, state or federal public authority.

**9. NOTICE REGARDING USE OF SERVICE FOR 911 OR OTHER EMERGENCY CALLS** — The Service provider hereunder does not interact with 911 and other emergency services in the same manner as land line telephone service. Depending on the circumstances of a particular call, the Service provided hereunder may not be able to identify your location to emergency services and may not always be connected to the appropriate emergency services provider. Customer agrees to hold company harmless against any and all claims, demands, actions or causes of action (including all actions by third parties) arising out of the use or attempted use of the company's service to access 911 or other emergency services.

**10. NO WARRANTY (SERVICE)** — Company makes no warranties, express or implied, including without limitation, any implied warranty of merchantability or fitness for a particular purpose to customer in connection with its use of the service. In no event shall company be liable for incidental or consequential damages to the full extent the same may be disclaimed by law. Customer acknowledges that service interruptions will occur from time to time and agrees to hold company harmless for all such interruptions.

**11. NO WARRANTY (EQUIPMENT)** — Company makes no warranties or representations of any kind, statutory, expressed or implied, to customer or any other purchaser of equipment activated on the service. Without limiting the foregoing, company specifically makes no express or implied warranties of merchantability or fitness for a particular purpose. Customer hereby waives all other warranties, guarantees, conditions or liabilities, express or implied, arising by law or otherwise. In no event shall company be liable for consequential, special or incidental damages, whether or not occasioned by

company negligence and including, without limitation, liability for any loss or damage resulting from the interruption or failure in the operation of any equipment activated on the service. There are no warranties which extend beyond the description contained herein. Customer assumes the entire risk as to the quality and performance of the equipment. If the equipment proves defective, the costs of all necessary servicing and repair will be borne by the customer.

12. NEXTEL BUSINESS NETWORKS -- There is no group call available on the Nextel Business Networks. There is no pooling of Nextel Direct Connect minutes between companies on the Nextel business networks. It is possible that participants on the Nextel Business Network could determine the private identification numbers of customer's units and be able to private call those units. It is also possible that users of customer units could determine the private identification numbers of other Nextel Business Network participants and private call them.

©2000 Nextel Communications, Inc. All rights reserved. Nextel, the Nextel logo, Nextel Direct Connect, and Nextel Business Networks are trademarks and/or service marks of Nextel Communications, Inc.

Ⓜ Motorola, *i2000* phone, VibraCall, and Call Alert, are trademarks; and iDEN and Turbo Dial are registered trademarks of Motorola, Inc.

©Reg. U.S. Pat. & Tm. Off.

---

## Safety and General Information

**IMPORTANT INFORMATION ON SAFE AND EFFICIENT OPERATION.**

**READ THIS INFORMATION BEFORE USING YOUR INTEGRATED MULTI-SERVICE PORTABLE RADIO.**

### **For the Safe and Efficient Operation of Your Radio, Observe These Guidelines:**

Your radio product contains a transmitter and a receiver. When it is *ON*, it receives and transmits radio frequency (RF) energy. The radio operates in the frequency range of 806 MHz to 870 MHz or 890 MHz to 960 MHz, and employs digital modulation techniques. When you communicate with your radio product, the system handling your call controls the power level at which your radio product transmits. The output power level typically may vary over a range from 0.00024 watts to 0.6 watts at, or below, 870MHz, and 0.001 watts to 3.2 watts at, or above, 890 MHz.

### **Exposure To Radio Frequency Energy**

Your Motorola Radio Product is designed to comply with the following national and international standards and guidelines regarding exposure of human beings to radio frequency electromagnetic energy:

- United States Federal Communications Commission, Code of Federal Regulations; 47 CFR part 2 sub-part J
- American National Standards Institute (ANSI) IEEE. C95. 1-1992
- National Council on Radiation Protection and Measurements (NCRP). Report 86
- International Commission on Non-Ionizing Radiation Protection (ICNIRP) 1998
- National Radiological Protection Board of the United Kingdom, GS 11, 1988
- Verband Deutscher Elektrotechniker (VDE) DIN-0848
- Department of Health and Welfare Canada. Safety Code 6

To assure optimal radio product performance and make sure human exposure to radio frequency electromagnetic energy is within the guidelines set forth in the above standards, always adhere to the following procedures:

When placing or receiving a phone call, or using the group and private call functions with a Group/Private Speaker OFF (muted speaker icon visible in the

display), hold your radio product as you would a telephone. Speak directly into the microphone and position the antenna up and over your shoulder.

When using your radio product as a traditional two-way radio while making group or private calls with the Group/Private Speaker ON (no speaker icon visible in the display), hold the radio product in a vertical position with the microphone one to two inches (2.5 to 5 cm) away from the lips.



For body-worn operation, with or without an earpiece or any other accessory, the antenna should be kept at least one inch (2.5 cm) from the body when transmitting. A Motorola accessory, a leather carry case with a belt clip, is available for body-worn use.

DO NOT hold the antenna when the radio is "IN USE". Holding the antenna affects call quality and may cause the radio product to operate at a higher power level than needed.

## **Interference to Medical and Personal Electronic Devices**

Most electronic equipment is shielded from RF energy. However, certain equipment may not be shielded against the RF signals from your radio product.

### *Pacemakers*

The Health Industry Manufacturers Association recommends that a minimum separation of 6 inches (15 cm) be maintained between a handheld wireless phone and a pacemaker to avoid potential interference with the pacemaker. These recommendations are consistent with the independent research by and recommendations of Wireless Technology Research.

Persons with pacemakers should:

- ALWAYS keep the radio product more than six inches from the pacemaker when the radio product is turned ON.
- Not carry the radio product in a breast pocket.
- Use the ear opposite the pacemaker to minimize the potential for interference.
- Turn the radio product OFF immediately if you have any reason to suspect that interference is taking place.

### *Hearing Aids*

Some radio products may interfere with some hearing aids. In the event of such interference, you may want to consult your hearing aid manufacturer to discuss alternatives.

### *Other Medical Devices*

If you use any other personal medical device, consult the manufacturer of your device to determine if it is adequately shielded from external RF energy. Your physician may be able to assist you in obtaining this information.

Turn your radio product OFF in health care facilities when any regulations posted in these areas instruct you to do so. Hospitals or health care facilities may be using equipment that could be sensitive to external RF energy.

### *Interference to Other Electronic Devices*

RF energy may affect improperly installed or inadequately shielded electronic operating and entertainment systems in motor vehicles. Check with the manufacturer or representative to determine if these systems are adequately shielded from external RF energy. Also check with the manufacturer of any equipment that has been added to the vehicle.

Turn your radio product OFF before boarding any aircraft to prevent possible interference to aircraft systems. Regulations of the United States Federal Communications Commission prohibit use when the plane is airborne. The United States Department of Transportation regulations require you have permission from a crew member to use your radio product while the plane is on the ground.

## **Safety and General**

### *Use While Driving*

Check the laws and regulations on the use of wireless telephones in the area where you drive. Always obey them.

When using the radio product while driving, please:

- Give full attention to driving and to the road
- Use hands-free operation, if available
- Pull off the road and park before making or answering a call if driving conditions so require.



## OPERATIONAL CAUTIONS

### Damaged Antennas

Do not use any portable radio product that has a damaged antenna. If a damaged antenna comes into contact with your skin, a minor burn can result.

### Batteries

All batteries can cause property damage and/or bodily injury such as burns if a conductive material such as jewelry, keys, or beaded chains touch exposed terminals. The conductive material may complete an electrical circuit (short circuit) and become quite hot. Exercise care in handling any charged battery, particularly when placing it inside a pocket, purse, or other container with metal objects.



## Operational Warnings

### Potentially Explosive Atmospheres

Turn off your radio product when you are in any area with a potentially explosive atmosphere, unless it is a radio product type especially qualified for use in such areas (for example, Factory Mutual Approved). Sparks in a potentially explosive atmosphere can cause an explosion or fire resulting in bodily injury, or even death.

**NOTE:** The areas with potentially explosive atmospheres referred to above include fueling areas such as: below decks on boats; fuel or chemical transfer or storage facilities; areas where the air contains chemicals or particles such as grain, dust or metal powders; and any other area where you would normally be advised to turn off your vehicle engine. Areas with potentially explosive atmospheres are often, but not always posted.

### Batteries

Do not replace or charge batteries in a potentially explosive atmosphere. Contact sparking may occur while installing or removing batteries and cause an explosion.

### Blasting Caps and Areas

To avoid possible interference with blasting operations, turn off your radio product when you are near electrical blasting caps, in a blasting area, or in areas posted: "Turn off two-way radio". Obey all signs and instructions.

### For Vehicles Equipped with an Air Bag

Do NOT place objects, including both installed and portable wireless equipment, in the area over the air bag or in the air bag deployment area. An air bag inflates with great force. If in-vehicle wireless equipment is improperly installed and the air bag inflates, serious injury could result.

### *Cleaning and Drying Considerations*

Using a leather carry case may help protect the surfaces and help prevent liquids (e.g., rain) from entering into the interior of the radio product. This product is not water proof, and exposing the unit to liquids may result in permanent damage to the unit.

If your radio product interior gets wet, do not try to accelerate drying with the use of an oven or a dryer as this will damage the radio product and void the warranty. Instead, do the following:

<b>1</b>	Immediately power off the radio product.
<b>2</b>	Remove Battery and SIM Card (if so equipped) from radio product.
<b>3</b>	Shake excess liquid from phone.
<b>4</b>	Place phone, battery and SIM card in an area that is at room temperature and has good air flow.
<b>5</b>	Let phone, battery and SIM card dry for 72 hours before reconnecting the SIM card and battery and/or powering on the phone.

If the phone does not work after following the steps listed above, contact your dealer for servicing information.

Clean the external surfaces of the radio product with a damp cloth, using a mild solution of dishwashing detergent and water. Some household cleaners may contain chemicals that could seriously damage the radio product. Avoid the use of any petroleum-based solvent cleaners. Also, avoid applying liquids directly on the radio product.

## Antenna Considerations

Use only the supplied or an approved antenna. Unauthorized antennas, modifications, or attachments could impair call quality, damage the radio product, or result in violation of local agency regulations.

## Accessory Safety Information

### IMPORTANT:

#### SAVE THESE ACCESSORY SAFETY INSTRUCTIONS

- Before using any battery or battery charger, read all the instructions for and cautionary markings on (1) the battery, (2) the battery charger, which may include a separate wall-mounted power supply or transformer, and (3) the radio product using the battery.
- Do not expose any battery charger to water, rain, or snow as they are designed for indoor or in-vehicle use only.

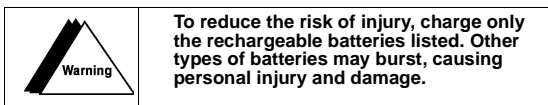

- To reduce the risk of damage to the cord or plug, pull by the plug rather than the cord when you disconnect the battery charger from the power source outlet.
- Do not operate any battery charger with a damaged cord or plug - replace them immediately.
- Battery chargers may become warm during operation, but not hot. If it becomes hot to the touch, unplug it from the power outlet immediately and discontinue its use.
- Use of a non-recommended attachment to a battery charger may result in a risk of fire, electric shock, or injury to persons.
- Make sure the battery charger power cord is located so that it will not be stepped on, tripped over, or subjected to damage or stress.
- An extension cord should not be used with any battery charger unless absolutely necessary. Use of an improper extension cord could result in a risk of fire and electric shock. If an extension cord must be used, make sure that:
  - The pins on the plug of the extension cord are the same number, size, and shape as those on the plug of the charger.
  - The extension cord is properly wired and in good electrical condition.
  - The cord size is 18AWG for lengths up to 100 feet and 16AWG for lengths up to 150 feet.
  - Do not operate any battery charger if it has received a sharp blow, has been dropped, or has been damaged in any way; take it to a qualified service technician.

- Do not disassemble a battery charger; take it to a qualified service technician when service or repair is required. Incorrect reassembly may result in a risk of electric shock or fire.
- Maximum ambient temperature around the power supply of the power supply or transformer should not exceed 40°C (104°F).
- The output power from the power supply or transformer must not exceed the rating given on the Desktop Dual-Pocket Charger.
- The disconnection from the line voltage is made by unplugging the power supply from the AC receptacle.
- To reduce risk of electric shock, unplug any battery charger from the outlet before attempting any maintenance or cleaning.
- For optimum charging performance, turn off the radio product while charging it in any battery charger.

## Warranty Information

**NOTE:**This Warranty applies within the fifty (50) united states and the District of Columbia

### Limited Warranty

#### Motorola Communication Products

##### I. WHAT THIS WARRANTY COVERS AND FOR HOW LONG:

MOTOROLA, INC. ("MOTOROLA") warrants the MOTOROLA manufactured iDEN Communication Products listed below ("Product") against defects in material and workmanship under normal use and service for a period of time from the date of purchase as scheduled below:

iDEN Subscriber Digital Mobile and Portable Units	One (1) Year
Product Accessories	One (1) Year

Rechargeable Batteries will be replaced during the applicable warranty period if:

the battery capacity falls below 80% of rated capacity, or

the battery develops leakage.

MOTOROLA, at its option, will at no charge either repair the Product (with new or reconditioned parts), replace it (with a new or reconditioned Product), or refund the purchase price of the Product during the warranty period provided it is returned in accordance with the terms of this warranty. Replaced parts or boards are warranted for the balance of the original applicable warranty period. All replaced parts of Product shall become the property of MOTOROLA.

This express limited warranty is extended by MOTOROLA to the original end user purchaser only and is not assignable or transferable to any other party. This is the complete warranty for the Product manufactured by MOTOROLA. MOTOROLA assumes no obligations or liability for additions or modifications to this warranty unless made in writing and signed by an officer of MOTOROLA. Unless made in a separate agreement between MOTOROLA and the original end user purchaser, MOTOROLA does not warrant the installation, maintenance or service of the Product.

MOTOROLA cannot be responsible in any way for any ancillary equipment not furnished by MOTOROLA which is attached to or used in connection with the Product, or for operation of the Product with any ancillary equipment, and all such equipment if expressly excluded from this warranty. Because each system which may use the Product is unique, MOTOROLA disclaims liability for range, coverage, or operation of the system as a whole under this warranty.

##### II. GENERAL PROVISIONS:

This warranty sets forth the full extent of MOTOROLA'S responsibilities regarding the Product, Repair, replacement or refund of the purchase price, at MOTOROLA'S options, is the exclusive remedy. THIS WARRANTY IS GIVEN IN LIEU OF ALL OTHER EXPRESS WARRANTIES. IMPLIED WARRANTIES, INCLUDING WITHOUT LIMITATION, IMPLIED WARRANTIES OF MERCHANTABILITY AND FITNESS FOR A PARTICULAR PURPOSE, ARE LIMITED TO THE DURATION OF THIS LIMITED WARRANTY. IN NO EVENT SHALL MOTOROLA BE LIABLE FOR

DAMAGES IN EXCESS OF THE PURCHASE PRICE OF THE PRODUCT, FOR ANY LOSS OF USE, LOSS OF TIME, INCONVENIENCE, COMMERCIAL LOSS, LOST PROFITS OR SAVINGS OR OTHER INCIDENTAL, SPECIAL OR CONSEQUENTIAL DAMAGES ARISING OUT OF THE USE OR INABILITY TO USE SUCH PRODUCT, TO THE FULL EXTENT SUCH MAY BE DISCLAIMED BY LAW.

**III. STATE LAW RIGHTS:**

SOME STATES DO NOT ALLOW THE EXCLUSION OR LIMITATION OF INCIDENTAL OR CONSEQUENTIAL DAMAGES, OR LIMITATION ON HOW LONG AN IMPLIED WARRANTY LASTS, SO THE ABOVE LIMITATIONS OR EXCLUSIONS MAY NOT APPLY.

This warranty gives specific legal rights, and there may be other rights which may vary from state to state.

**IV. HOW TO GET WARRANTY SERVICE:**

You must provide proof of purchase (bearing the date of purchase and Product item serial number) in order to receive warranty service and, also, deliver or send the Product item, transportation and insurance prepaid, to an authorized warranty service location. Warranty service will be provided by MOTOROLA through one of its authorized warranty service locations. If you first contact the company which sold you the Product (e.g., dealer or communication service provider), it can facilitate your obtaining warranty service. You can also call MOTOROLA at 1-800-453-0920 for warranty service location information.

**V. WHAT THIS WARRANTY DOES NOT COVER:**

- a. Defects or damage resulting from use of the Product in other than its normal and customary manner.
- b. Defects or damage from misuse, accident, water, or neglect.
- c. Defects or damage from improper testing, operation, maintenance, installation, alteration, modification, or adjustment.
- d. Breakage or damage to antennas unless caused directly by defects in material workmanship.
- e. A Product subjected to unauthorized Product modifications, disassemblies or repairs (including, without limitation, the addition to the Product of non-MOTOROLA supplied equipment) which adversely affect performance of the Product or interfere with MOTOROLA'S normal warranty inspection and testing of the Product to verify any warranty claim.
- f. Product which has had the serial number removed or made illegible.
- g. Rechargeable batteries if:
  - 1. Any of the seals on the battery enclosure of cells are broken or show evidence of tampering.
  - 2. The damage or defect is caused by charging or using the battery in equipment or service other than the Product for which it is specified.
- h. Freight costs to the repair depot.
- i. A Product which, due to illegal or unauthorized alteration of the software/firmware in the Product, does not function in accordance with MOTOROLA'S published specifications or the FCC type acceptance labeling in effect for the Product at the time the Product was initially distributed from MOTOROLA.

- j. Scratches or other cosmetic damage to Product surfaces that does not effect the operation of the Product.
- k. Normal and customary wear and tear.

## **VI. PATENT AND SOFTWARE PROVISIONS:**

MOTOROLA will defend, at its own expense, any suit brought against the end user purchaser to the extent that it is based on a claim that the Product or parts infringe a United States patent, and Motorola will pay those costs and damages finally awarded against the end user purchaser in any such suit which are attributable to any such claim, but such defense and payments are conditioned on the following:

- a. That MOTOROLA will be notified promptly in writing by such purchaser of any notice of such claim;
- b. That MOTOROLA will have sole control of the defense of such suit and all negotiations for its settlement or compromise; and
- c. Should the Product or parts become, or in MOTOROLA'S opinion be likely to become, the subject of a claim of infringement of a United States patent, that such purchaser will permit MOTOROLA, at its option and expense, either to procure for such purchaser the right to continue using the Product or parts or to replace or modify the same so that it becomes non-infringing or to grant such purchaser a credit for the Product or parts as depreciated and accept its return. The depreciation will be an equal amount per year over the lifetime of the Product or parts as established by MOTOROLA.

MOTOROLA will have no liability with respect to any claim of patent infringement which is based upon the combination of the Product or parts furnished hereunder with software, apparatus or devices not furnished by MOTOROLA, nor will MOTOROLA have any liability for the use of ancillary equipment or software not furnished by MOTOROLA which is attached to or used in connection with the Product or any parts thereof.

Laws in the United States and other countries preserve for MOTOROLA certain exclusive rights for copyrighted MOTOROLA software, such as the exclusive rights to reproduce in copies and distribute copies of such MOTOROLA software. MOTOROLA software may be used in only the Product in which the software was originally embodied and such software in such Product may not be replaced, copied, distributed, modified in any way, or used to produce any derivative thereof. No other use including, without limitation, alteration, modification, reproduction, distribution, or reverse engineering of such MOTOROLA software or exercise of rights in such MOTOROLA software is permitted. No license is granted by implication, estoppel or otherwise under MOTOROLA patent rights or copyrights.

**Limited Warranty**

<b>NOTE:</b>	This Warranty applies in Singapore and the Philippines.
--------------	---

**Motorola Communication Products**

**I. WHAT THIS WARRANTY COVERS AND FOR HOW LONG:**

MOTOROLA warrants the MOTOROLA manufactured iDEN Communication Products listed below (“Product”) against defects in material and workmanship under normal use and service for a period of time from the date of purchase as scheduled below:

iDEN Subscriber Digital Mobile and Portable Units	One (1) Year
Product Accessories (manufactured by or under license from MOTOROLA)	One (1) Year

Rechargeable Batteries will be replaced during the applicable warranty period if: the battery capacity falls below 80% of rated capacity, or the battery develops leakage.

MOTOROLA, at its option, will at no charge either repair the Product (with new or reconditioned parts), replace it (with a new or reconditioned Product), or refund the purchase price of the Product during the warranty period provided it is returned in accordance with the terms of this warranty. Replaced parts or boards are warranted for the balance of the original applicable warranty period. All replaced parts of Product shall become the property of MOTOROLA.

This express limited warranty is extended by MOTOROLA to the original end user purchaser only and is not assignable or transferable to any other party. This is the complete warranty for the Product manufactured by MOTOROLA. MOTOROLA assumes no obligations or liability for additions or modifications to this warranty unless made in writing and signed by an officer of MOTOROLA. Unless made in a separate agreement between MOTOROLA and the original end user purchaser, MOTOROLA does not warrant the installation, maintenance or service of the Product.

MOTOROLA cannot be responsible in any way for any ancillary equipment not furnished by MOTOROLA which is attached to or used in connection with the Product, or for operation of the Product with any ancillary equipment, and all such equipment if expressly excluded from this warranty. Because each system which may use the Product is unique, MOTOROLA disclaims liability for range, coverage, or operation of the system as a whole under this warranty.

**II. GENERAL PROVISIONS:**

This warranty sets forth the full extent of MOTOROLA’S responsibilities regarding the Product. Repair, replacement or refund of the purchase price, at MOTOROLA’S options, is the exclusive remedy. THIS WARRANTY IS GIVEN IN LIEU OF ALL OTHER EXPRESS WARRANTIES. IMPLIED WARRANTIES, INCLUDING WITHOUT LIMITATION, IMPLIED WARRANTIES OF MERCHANTABILITY AND FITNESS FOR A PARTICULAR PURPOSE, ARE LIMITED TO THE DURATION OF THIS LIMITED WARRANTY TO THE FULL EXTENT SUCH MAY BE DISCLAIMED BY LAW. IN NO EVENT SHALL MOTOROLA BE LIABLE FOR DAMAGES IN

EXCESS OF THE PURCHASE PRICE OF THE PRODUCT, FOR ANY LOSS OF USE, LOSS OF TIME, INCONVENIENCE, COMMERCIAL LOSS, LOST PROFITS OR SAVINGS OR OTHER INCIDENTAL, SPECIAL OR CONSEQUENTIAL DAMAGES ARISING OUT OF THE USE OR INABILITY TO USE SUCH PRODUCT, TO THE FULL EXTENT SUCH MAY BE DISCLAIMED BY LAW.

### **III. HOW TO GET WARRANTY SERVICE:**

You must provide proof of purchase (bearing the date of purchase and Product item serial number) in order to receive warranty service and, also, deliver or send the Product item, transportation and insurance prepaid, to an authorized warranty service location. Warranty service will be provided by MOTOROLA through one of its authorized warranty service locations. If you first contact the company which sold you the Product (e.g., dealer or communication service provider), it can facilitate your obtaining warranty service.

### **IV. WHAT THIS WARRANTY DOES NOT COVER:**

- a. Defects or damage resulting from use of the Product in other than its normal and customary manner.
- b. Defects or damage from misuse, accident, water, or neglect.
- c. Defects or damage from improper testing, operation, maintenance, installation, alteration, modification, or adjustment.
- d. Breakage or damage to antennas unless caused directly by defects in material workmanship.
- e. A Product subjected to unauthorized Product modifications, disassemblies or repairs (including, without limitation, the addition to the Product of non-MOTOROLA supplied equipment).
- f. Product which has had the serial number removed or made illegible.
- g. Rechargeable batteries if:
  - 1. Any of the seals on the battery enclosure of cells are broken or show evidence of tampering.
  - 2. The damage or defect is caused by charging or using the battery in equipment or service other than the Product for which it is specified.
- h. Freight costs to the repair depot.
- i. A Product which, due to illegal or unauthorized alteration of the software/firmware in the Product, does not function in accordance with MOTOROLA'S published specifications or the local type acceptance labeling in effect for the Product at the time the Product was initially distributed from MOTOROLA.
- j. Scratches or other cosmetic damage to Product surfaces that does not effect the operation of the Product.
- k. Normal and customary wear and tear.
- l. Exclusion for defects or damage arising from use of the products in connection with non-MOTOROLA equipment.

### **V. PATENT AND SOFTWARE PROVISIONS:**

MOTOROLA will defend, at its own expense, any suit brought against the end user purchaser to the extent that it is based on a claim that the Product or parts infringe a patent, and Motorola will pay those costs and damages finally awarded against the end user purchaser in any such suit which are attributable to

---

any such claim, but such defense and payments are conditioned on the following:

- a. That MOTOROLA will be notified promptly in writing by such purchaser of any notice of such claim;
- b. That MOTOROLA will have sole control of the defense of such suit and all negotiations for its settlement or compromise; and
- c. Should the Product or parts become, or in MOTOROLA'S opinion be likely to become, the subject of a claim of infringement of a patent, that such purchaser will permit MOTOROLA, at its option and expense, either to procure for such purchaser the right to continue using the Product or parts or to replace or modify the same so that it becomes non-infringing or to grant such purchaser a credit for the Product or parts as depreciated and accept its return. The depreciation will be an equal amount per year over the lifetime of the Product or parts as established by MOTOROLA.

MOTOROLA will have no liability with respect to any claim of patent infringement which is based upon the combination of the Product or parts furnished hereunder with software, apparatus or devices not furnished by MOTOROLA, nor will MOTOROLA have any liability for the use of ancillary equipment or software not furnished by MOTOROLA which is attached to or sued in connection with the Product or any parts thereof. In no event shall MOTOROLA be liable for any incidental, special or consequential damages arising from any claim of patent infringement or alleged infringement.

Laws in the United States and other countries preserve for MOTOROLA certain exclusive rights for copyrighted MOTOROLA software, such as the exclusive rights to reproduce in copies and distribute copies of such MOTOROLA software. MOTOROLA software may be used in only the Product in which the software was originally embodied and such software in such Product may not be replaced, copied, distributed, modified in any way, or used to produce any derivative thereof. No other use including, without limitation, alteration, modification, reproduction, distribution, or reverse engineering of such MOTOROLA software or exercise of rights in such MOTOROLA software is permitted. No license is granted by implication, estoppel or otherwise under MOTOROLA patent rights or copyrights.

## Patent and Trademark Information

This product is protected under one or more of the following patents:

4817157, 4896361, 4857928, 5041793, 5060294, 5066923, 5134718, 5140156, 5239963, 5257411, 5287387, 5265219, 5289504, 5316168, 5317247, 5338396, 5389927, 5406588, 5424921, 5457376, 5460906, 5551063, 5557079, 5596487, 5615412, 5638403, 5559468, 5469465, 5170413, 5140615, 5519730, 5241544, 5584059, 5574992, 5396656, 5487091, 5533004, 5299199, 5343499, 5369501, 5509031, 5515379, 5528723, 5598417, 5066923, 5241650, 5278833, 5359696, 5548631, 5410632, 5440582, 5457735, 5457818, 5471670, 5477550, 5481537, 5566181, 5229767, 5208804, 5295140, 5381449, 5440590, 5467398, 5490230, 5620242, 5623523, 5655913, 5675281, 5715240, 5771440, 5854578, 5721787, 5729539, 5788523, 5869204, 5911124, 5946620, 5949774, 5949821, 5951317, 5987332, 6002948

Additional patents are pending.

© 2000 Nextel Communications, Inc. All rights reserved. Nextel, the Nextel logo, Nextel Worldwide, Nextel Direct Connect, and Nextel Business Networks are trademarks and/or service marks of Nextel Communications, Inc. [www.nextel.com](http://www.nextel.com).

™, Motorola, iDEN, Call Alert, *i2000* phone, TurboDial, VibraCall, and Message Mail are trademarks or registered trademarks of Motorola, Inc.

®Reg. U.S. Pat. & Tm. Off.

All other trademarks mentioned in this manual are trademarks of their respective companies.

### **IMPORTANT!**

Be sure to read "Safety and General Information" on page 103 before using your Nextel phone.

© Copyright 2000, Motorola, Inc. All rights reserved.

---

# Index

## A

- Accessing New Pages 63
- Accessories 91
  - Audio Adapter 96
  - Batteries 91
  - Cigarette Lighter Adapter 93
  - Desktop Dual-Pocket Charger 95
  - Leather Carry Case 91
  - Travel Charger 92
- Activating Your Greeting Schedule 50
- Active Line Indicator 22
- Additional Phone Services 55
  - 3-Way Calling 57
  - Call Forwarding 57
  - Call Hold 56
  - Call Waiting 55
  - Transferring Calls to Voice Mail 58

- Antenna Considerations 108
- Attaching/Detaching the Earpiece Microphone 96
- Automatic Redial 34

## B

- Battery
  - Attaching 12
  - Detaching 12
- Battery Operating Instructions 92
- Battery Strength Indicator Icon 22
- Business Networks 73

## C

- Call Alert Queuing 77
- Call Forward Indicator 22
- change the case of the letter 27
- Changing the PIN 15
- Changing Your Password 44
- Charge Strength 13
- Charging the Battery 12
- Cleaning Instructions 106

- Create/Modify Message Forwarding Number 52
- Creating Group Lists 50
- Customizing the i2000 Phone 80
  - Changing the Display Language 80
  - Programming Menus 80, 86
  - Selecting a Ring Style 80, 83
  - Setting the Ringer Volume 80
  - Setting the Time and Date Format 81
- Customizing Your Voice Mail Setup 44

## D

- Delayed Forwarding of messages 52
- Deleting a Group List 51
- Dialing 32
- Direct Dial 32
- Display Icons 22
- Displaying the Caller's Name 58
- Displaying Your Phone Number 32

## E

- E-Mail Paging 65
- Emergency 34
- Enabling/Disabling Message Forwarding 52
- Enabling/Disabling Pager Notification 54
- Entering the PIN 14
- Entering the Private ID 74
- Erasing List Entries 31
- retrieve deleted messages 43

## F

- Forwarding
  - modify type 53
- Future Delivery 48

## G

- Getting Started
  - Activating Your i2000 Phone 11

- Display Icons 22
- Inserting the SIM Card 20
- Modes and Menus 23
- SIM Card PIN 14
- Your Nextel Phone Status 21
- Greetings 48
- Group Calls 77
- Group Lists 47, 50
- Group Mode 23, 25
- Group/Prvt Vibe 84
- Group-Silent Programming 78
- H**
- How to Use This User's Guide 2
- I**
- iDEN Organizer 26
- Immediate Forwarding 52
- International Phone Numbers 35
- L**
- Light Sensor 18
- Limiting Notification to Specific Times 54
- Listening Options 41
  - Quick Reference List 43
- M**
- Mail Vibe 84
- Mailbox Numbers 47
- Making Calls From the Stored List 33
- menu options 23
- Message
  - Delivery Status
    - checking 65
  - message options 42
- Mode 23
- Modes and Menus 23
- Modify Forwarding Type 53
- Modifying a Group List 51
- N**
- Name Search 33
- New Message Indicators 39
- New Text and Numeric Paging Flashing Indicator 22
- Nextel
  - Business Networks 90
  - Customer Care 90
  - Direct ProtectSM insurance 90
  - Internet Home Page 90
  - Nextday Accessories 90
  - Terms and Conditions of Service 100
  - Nextel Business Networks 73
  - Nextel Direct Connect 23, 73
  - Nextel NextdaySM Accessories 26
  - Nextel Voice Mail Service 38
  - Nextel Worldwide Network
    - Searching for a Network 67
    - Storing New Networks to Your Known List 71
  - Non-Emergency 34
  - Notification of Non-Delivery 48
  - Numeric Paging 65
  - O**
  - Operator Assisted
    - Paging 65
  - Ordering Information 90
  - P**
  - Pager Notification 53
  - Paging
    - E-mail 65
    - Numeric 62, 65
    - Operator Assisted 65
    - Web 65
  - password 39
  - Patent and Trademark Information 116
  - Per-Call Blocking 59
  - Per-Line Blocking 59
  - Phone Calls 31
  - Phone Mode 23, 31
    - Hands-Free Speakerphone 35
    - Last 10 Numbers Received/Sent Call List 37
    - Making Phone Calls 32
    - Missed Call Indicator 36
    - Programming Your Own Phone Number 31
    - Receiving a Phone Call 36

- Selecting a Ring Style 83
- Phone Settings 80
- Phone Status 22
- Phone Vibrate 84
- Phone Vibrate/Ring 84
- PIN 14, 16
  - Disabling 17
  - Enabling 17
  - Unblocking 16
- Placing/Clearing a Call Alert in the Queue 77
- Privacy Issues 58
- Private 48
- Private Calls 74
- Private IDs
  - Quickstore 75
- Private Mode 23, 25
- Private/Group Mode 73
- Private/Group Speaker Indicator 22
- Programming Your Own Phone Number 38
- PUK
  - Resetting the SIM PIN 16
- Q**
- Questions? 7
- Quick Guide
  - Group Mode 25
  - i2000 Phone Functions 24
  - Phone Mode 24
  - Private Mode 25
- Quickstore of Private IDs 75
- R**
- Receiving a Group Call 78
- Receiving Private Calls 75
- Receiving/Responding to a Call Alert 76
- Recording and Sending A Message 47
- Recording Your Active Greeting 45
- Recording Your Name 45
- Redial 34
- Removing the Audio Adapter 96
- Removing the Cigarette Lighter Adapter 94
- Responding to a Call Alert within the Queue 77
- Reviewing/Storing Received Calls 38
- S**
- Safety and General Information 103, 110
- Sample Greeting 45
- Saving and Deleting Messages 43
- Screens
  - Adding GSM Network 71
  - Alternate Lines 60
  - Display Language 80
  - Group Mode 25
  - PIN
    - Change 15
    - Disabling 17
    - Enabling 17
    - New 16
  - PIN Unblocking 16
  - Private List Store 27
  - Private Mode 25
  - Reselecting Phone System 67
  - Ring Style 83
  - Ringer Volume 83
  - Searching a Network 67
  - Storing Your Own Number 32
  - Unanswered Phone Calls 36
- Scroll 33
- Selecting a Name from a Stored List 75
- Sending a Call Alert 76
- Sending a Page 64
- Setting the Time and Date Format 81
- Setting Up Your Voice Mailbox 39
- Signal Strength Indicator 22
- silence incoming alerts and voice 79
- Silent Forwarding 52
- SIM 14
  - Initial PIN number 14
- Special Delivery Options 48
- Speed Dial 33
- Status Light 21
- Status Messages 98

status of your connection 21  
stored list 26

**T**

Talkgroup  
  Naming 78  
Text and Numeric Paging  
  Auto Call Back 64  
Time and Date Charts 53  
Turbo Dial 34  
Turning Off Call Forwarding 58  
Turning On Call Forward 57  
Turning Your i700plus On/Off 13  
two-way radio 73

**U**

Urgent 48  
Using the Cigarette Lighter Adapter  
94  
Using Your Phone As A Modem 66

**V**

VibraCall Settings 84  
VibraCall™ Indicator 22  
Vibrate Alert 84  
View Page Immediately 63  
Voice Mail  
  24-hour Military Time Clock  
  53  
  Changing Your Password 44  
  Indicator 22  
Voice Mail Features  
  Advanced 47  
Voice Mail Menus 40  
Voice Mailbox 39

**W**

Warranty Information 110  
Web Paging 64